

Pre-Installation Guide

68/85 Polymer

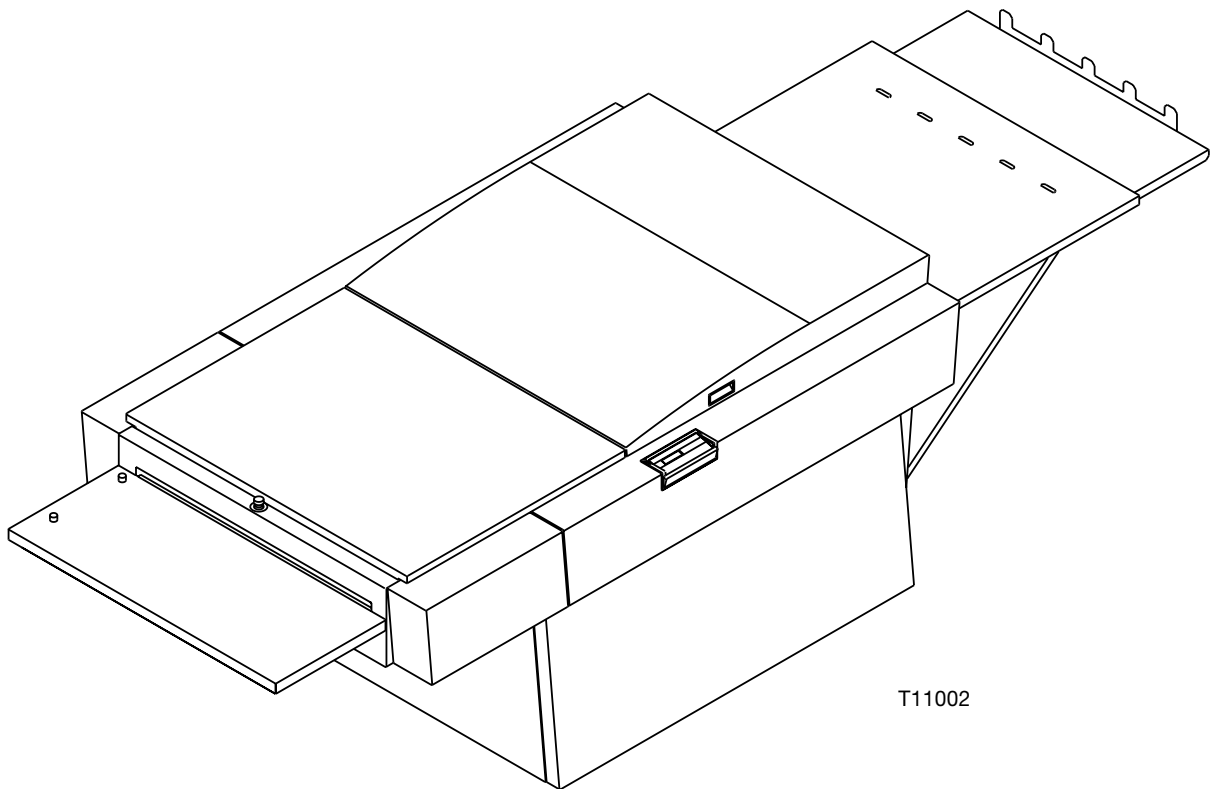

T11002

0. Scope

Processor models

This guide covers the following plate processor types:
Polymer Processors.

Symbols

Symbols used throughout this manual is explained below:



WARNING!

Observe and/or act according to the information in order to avoid any personnel injury or environmental damage.



CAUTION!

Observe and/or act according to the information in order to avoid any mechanical or electrical damage to the equipment.



NOTE!

Observe and/or act according to the information in order to obtain the best possible function of the equipment.

1. Introduction

Pre-Installation Instructions

The instructions in this Pre-Installation Guide allow the customer and the Service Technician to prepare the installation of the plate processor.

Contents

The Pre-Installation Guide covers the following subjects:

Subject	See...
2. When The Processor Arrives	page 5
3. Transporting The Processor	page 7
4. General Requirements For The Installation Site	page 8
5. Requirements For Power Supply	page 11
6. Pre-Installation Checklist	page 14



Only qualified Service Technicians are allowed to unpack and install the processor.

2. When The Processor Arrives

Storing the processor before installation

The crated processor will usually be delivered some time before the arrival of the Service Technician. In such a case you should prepare an appropriate place indoors to store the crated processor.

The crate

Below are the dimensions and weight of the crated processor:

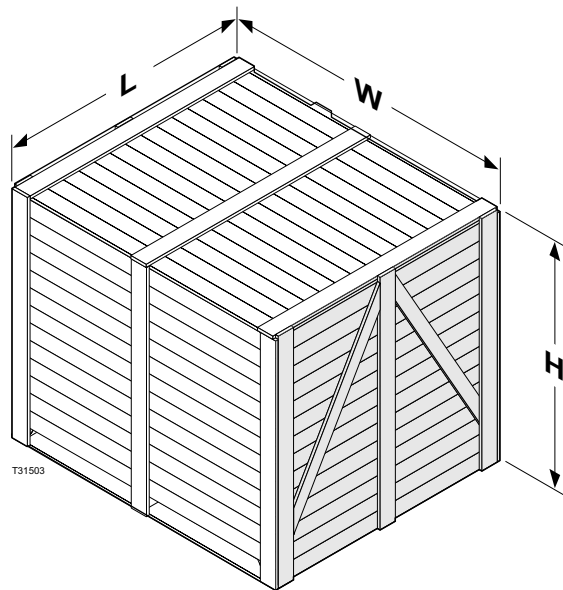

Processor Type	68	85
Length (L)	2118 mm (83.4")	2118 mm (83.4")
Width (W)	1170 mm (46.1")	1345 mm (53.0")
Height (H)	1355 mm (53.3")	1355 mm (53.3")
Weight*, incl. processor w. pre-heat and pre-wash	370 kg (816 lbs)	430 kg (948 lbs)
Weight* processor	265 kg (584 lbs)	307 kg (677 lbs)

*) w.o. tables, w. 3 brushes, (85: w. filter in dev.)

Checking for damage

Check if the crate is damaged at the time of delivery. Report any damage to the crate to the transport company. Take note of the damage before you allow the Service Technician to unpack the processor. Provide a detailed description or take a photograph of the damage.

Handling the crate

The icons on the crate indicate how to handle the crate during transport and storage:

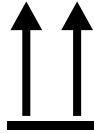

Ensure that the side indicated by the arrows is always up.



Handle the crate with care.



Never expose the crate to water, or place it in a high-humidity area.

3. Transporting The Processor

Lifting the crate

To lift the crate, at least a fork-lift truck or two persons and a hand powered pallet mover are required.



Please note that you can only insert the forks of the fork-lift truck or pallet mover from the side as illustrated below.

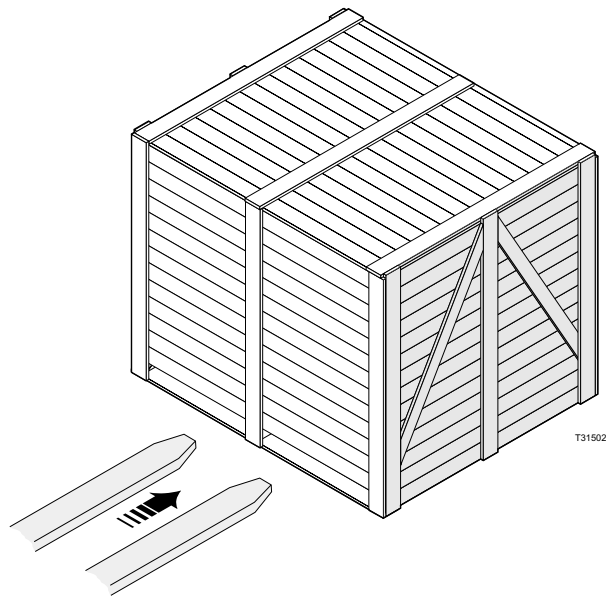

Available width for transport

Depending of the width of the door(s) through which the processor has to be transported to the installation site, the Service Technician may have to perform the actions described in the table below:

If width of the door is...

68	85	Then...
> 1230 mm (48.4")	> 1400 mm (55.1")	No action is required as the crated processor can be transported immediately to the installation site.
< 1230 mm (48.4") - > 1100 mm (43.3")	< 1400 mm (55.1") - > 1250 mm (49.2")	The Service Technician has to unpack the processor.
< 1100 mm (43.3")	< 1250 mm (49.2")	The Service Technician has to unpack and strip down the processor.

4. General Requirements For The Installation Site

Environmental requirements



Provide a heating and ventilating system capable of maintaining room temperature between 15 and 25°C (59 and 77°F) and relative humidity on max. 80%.

Heat emission from the processor is max. 10600 BTU.

Cleaning facilities

It is essential to have easy access to a sink and a water tap with hot water where rollers, guides, and brushes can be washed.

The minimum recommended size of the sink is:

68 cm processors: 90 x 40 cm (35.4 x 16")

85 cm processors: 100 x 40 cm (39.4 x 16")

Space requirements

Decide where the processor shall be placed and make sure that the free space around the machine makes servicing possible.

The recommended minimum free space around the machine is specified in the illustration below:

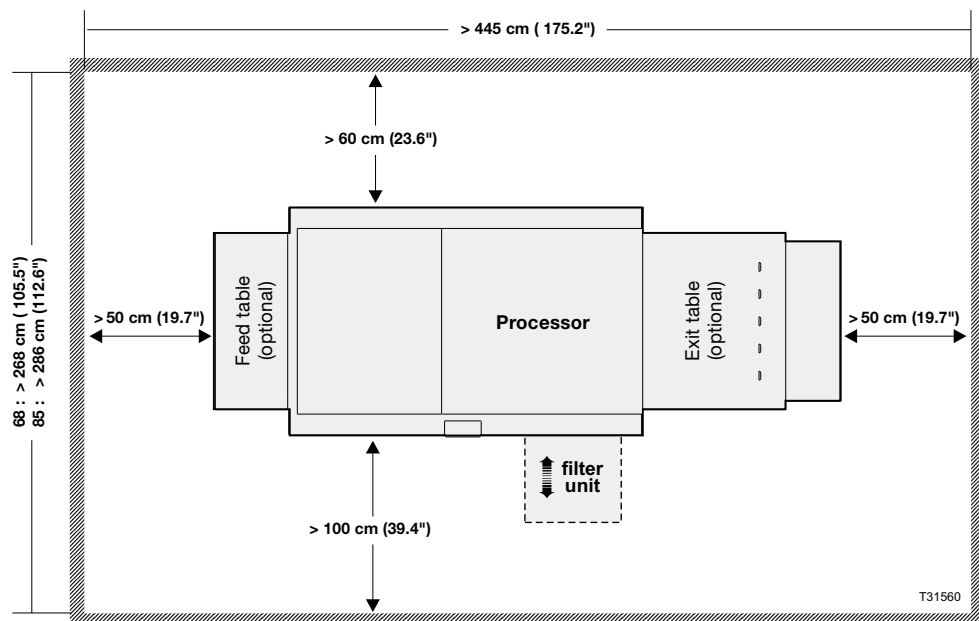

For CTP On-line processors the space requirements at the processor front has to be decided separately.

Processor dimensions

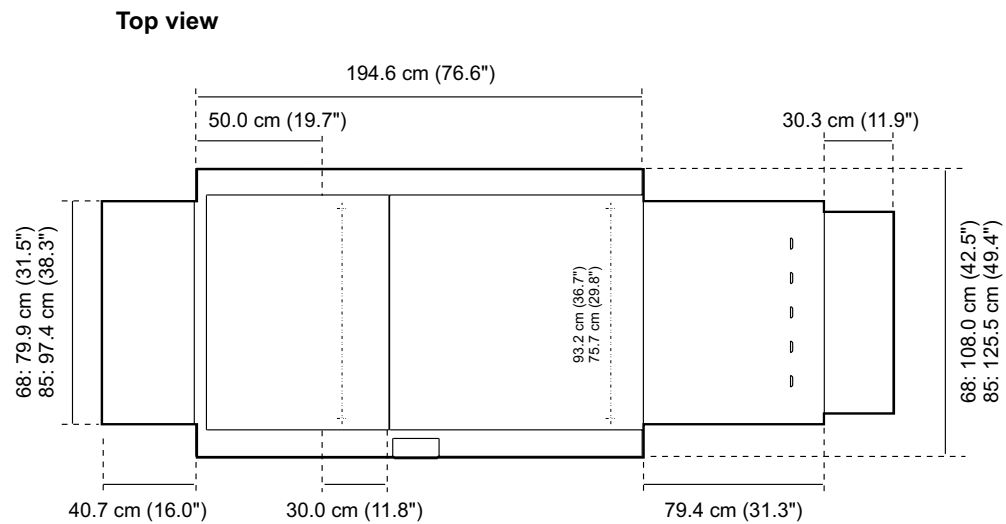
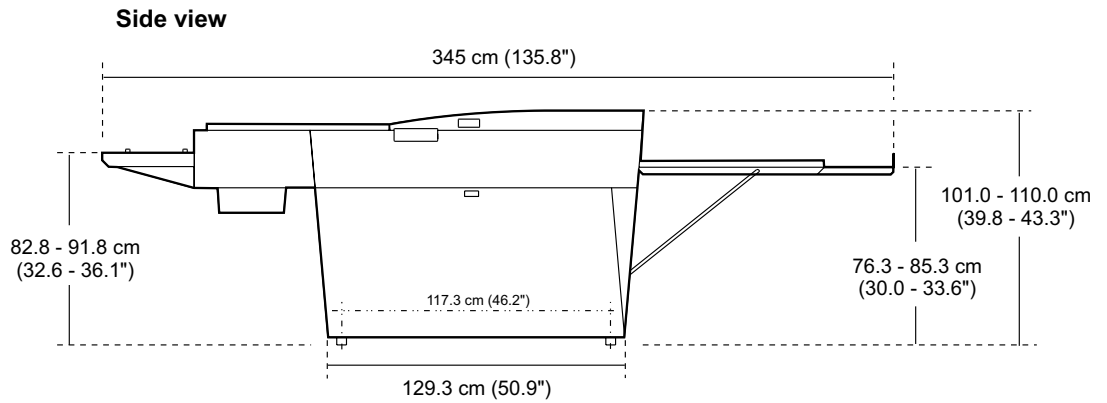

T31561

Water supply and drain requirements

The water supply connection is located underneath the processor as illustrated below.

Water supply:

The supply water pressure must be **1 - 6 bar (15 - 87 psi)**.

Drains:

- The Developer drain must be led to a waste container.
- The wash drain can be led to public drain. Refer to local regulations.
- The gum must be drained into a container and recirculated.



CAUTION! When establishing central reception systems for waste chemicals, copper or brass should not be used in the drainage system as the chemicals involved are highly corrosive. Therefore plastic or rubber is recommended. Check with the chemicals supplier for details.



Never lead drain hoses from the developer or gum section into a drain, as most solutions are strong pollutants and it is strictly forbidden to empty this type of chemicals into the public sewer system.

In any case the local regulations applying to the treatment of (chemical) waste must be followed strictly.

Please also refer to the processor dimensions described earlier in this document.

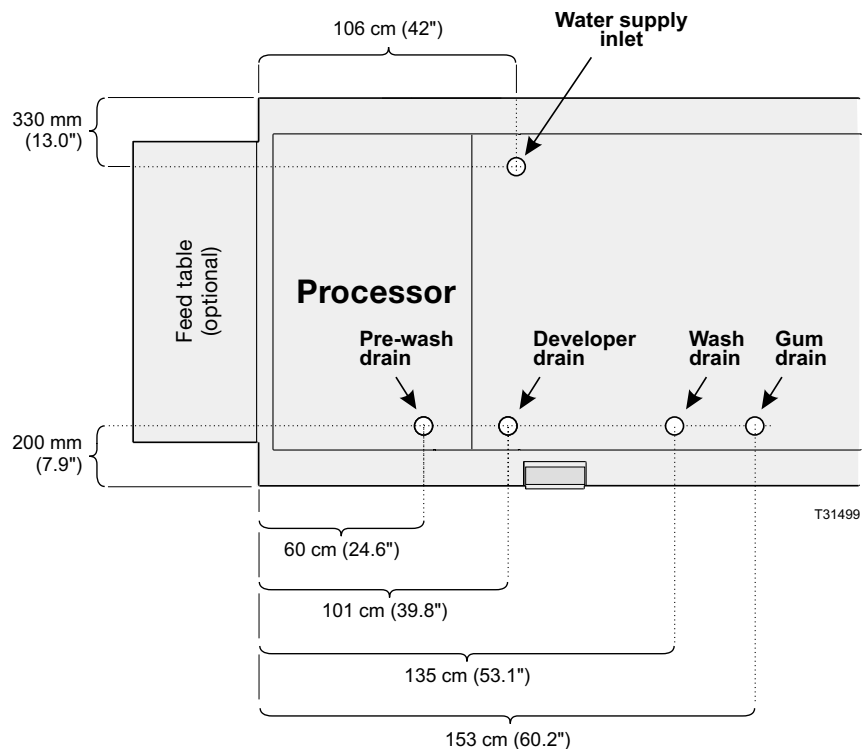

5. Requirements For Power Supply



Electrical installation must conform to local regulations and guidelines.

Main power connection

The main power connection must be made in the processor's field-wiring box located on the right side of the processor below the main switch (see illustration below).

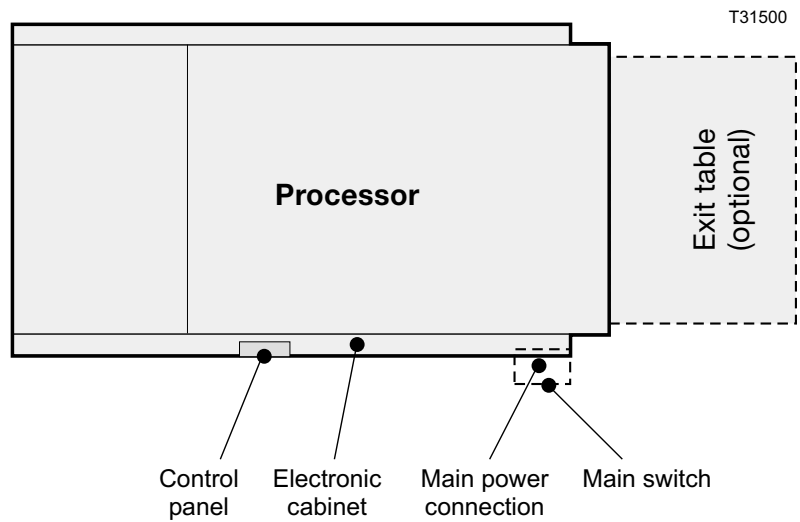

Supplies

The cable for the main power connection is not delivered with the processor.

Main power outlet

Provide a main power outlet close to the installation site. The table below indicates the applicable power supply types and to which processor models they apply. The table also shows recommended power supply cables:

	Supply/Fuse	Recom. cable type	68	85
EUR	3W + N + PE ~400V / 3x12 Amps, 50-60 Hz	Min. 5 x 1.5 mm ² , type H07 RNF	●	●
US	Single Phase, 2W + PE 230V / 2x23 Amps, 50-60 Hz	Min. 3 x 10 AWG, type SJO	●	●
	3 Phases, 3W + PE 230V / 3x17 Amps, 50-60 Hz	Min. 4 x 12 AWG, type SJO	●	●
JAP	Single Phase, 2W + PE 200V / 2x23 Amps, 50-60 Hz	Min. 3 x 10 AWG, type SJO	●	●
	3 Phases, 3W + PE 200V / 3x17 Amps, 50-60 Hz	Min. 4 x 12 AWG, type SJO	●	●

Voltage tolerance : +/- 10%

Max. power cons. : 5400 Watts

Heat dissipation,

average - stand-by : Approx. 2000 Watts ~ 6824 BTU/hour

average - operation : Approx. 5400 Watts ~ 18426 BTU/hour



The processor is Class 1 equipment. Therefore, the processor must be connected to earth to avoid electrical shocks.

Cables



When deciding what type of cable to use take into account the chemical resistance (chemicals may leak onto cable) and the mechanical resistance (operator may step onto cable).

The conductors in the power supply cable should be of copper.

Provide for additional cable protection, e.g. cable covers, if cable is exposed to heavier transport such as fork-lift trucks etc.

Fuses



The fuses must have a breaking capacity of min. 100kA. If using automatic circuit breakers make sure that they are Type D.

6. Pre-Installation Checklist

Please ask the customer to answer the following questions in order to ensure a trouble-free installation of the processor:

- | 1. Delivery of the crate and transport to the installation site | YES | NO |
|--|--------------------------|--------------------------|
| A. Is there a place indoors where the packing box can be stored temporarily? | <input type="checkbox"/> | <input type="checkbox"/> |
| B. Is there a hand-powered pallet mover, a fork-lift truck or any other lifting device available? | <input type="checkbox"/> | <input type="checkbox"/> |
| C. Can the crate be transported directly to the installation site?
<i>See minimum width specifications on page 7.</i> | <input type="checkbox"/> | <input type="checkbox"/> |
| D. Is it sufficient to unpack the processor before it is transported to the installation site?
<i>See minimum width specifications on page 7.</i> | <input type="checkbox"/> | <input type="checkbox"/> |
| E. Are there other factors (stairs, elevators, corners, obstacles, etc.) which should be taken into account when transporting the crate or processor?
If so, explain: | <input type="checkbox"/> | <input type="checkbox"/> |
| | | |
| | | |
| | | |

2. Power supply

- | | | |
|--|--------------------------|--------------------------|
| A. Make a note of the present supply specifications: | | |
| No. of Phases | Voltage V | Fused by Amps |
| Neutral Wire? | Earth Wire? | Frequency Hz |
| | YES | NO |
| B. Has a connection box been provided to connect the processor to the mains? | <input type="checkbox"/> | <input type="checkbox"/> |
| C. Is the customer aware that he/she should provide (or order) all supplies (cables, fuses, etc.) necessary to connect the processor to the mains? | <input type="checkbox"/> | <input type="checkbox"/> |
| D. Is there a house electrician available? | <input type="checkbox"/> | <input type="checkbox"/> |
| E. Are there any known problems in the building where the processor will be installed?
If so, explain: | <input type="checkbox"/> | <input type="checkbox"/> |
| | | |
| | | |
| | | |

3. Water supply and drain

YES NO

- A. Capacity of air condition/ventilation adequate with regard to BTU max. 10600? YES NO
- B. Can a hose 3/4"RG-11.5NH or 3/4"x3/4" be connected to the water supply tap? YES NO
- C. Is there a large sink (with hot water) for cleaning the equipment? YES NO
- D. Will the processor be connected to a local waste treatment system? YES NO
- E. Is the tap water temperature adjustable? (If recommended by plate supplier). YES NO
- F. Does the supply water pressure lie between 1 and 6 bar (15 and 87 psi)? YES NO
- G. Availability of warm water for cleaning of processor? YES NO

4. Disposition of the various supplies and equipment on the installation site:

A large rectangular area filled with a fine grid of small squares, intended for drawing or taking notes regarding the installation site.

