

Pre-installation Manual



Cleaning Unit⁺
85/120

Pre-installation Manual

Cleaning Unit+ 85/120

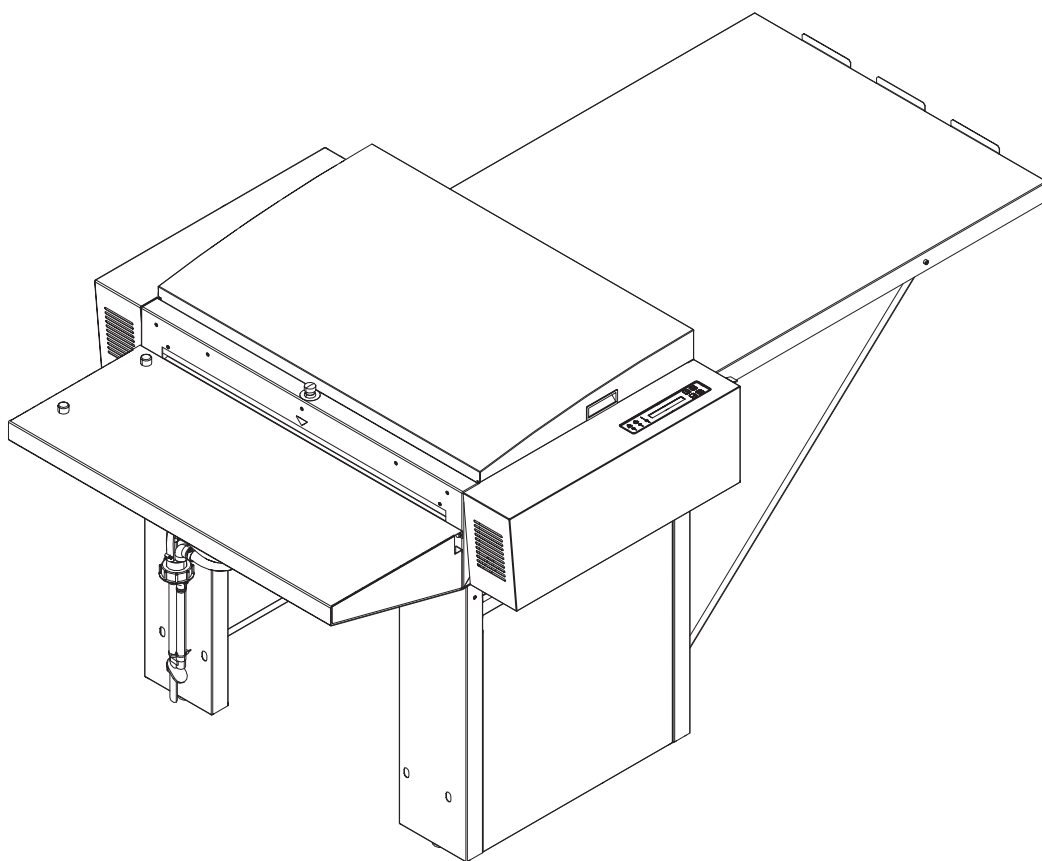

This manual is published by: **GLUNZ & JENSEN A/S**
Haslevvej 13
DK-4100 Ringsted
Denmark
Phone: +45 5768-8181
E-mail: gjhq@glunz-jensen.com
Internet: www.glunz-jensen.com

Copyright © 2012 by GLUNZ & JENSEN A/S.

Part 0: Introduction

Reservations

- This manual was written and illustrated using the best possible information available at the time of publication.
- Any differences between this manual and the equipment reflect improvements introduced after the publication of the manual.
- Changes, technical inaccuracies and typographic errors will be corrected in subsequent editions.
- As a part of our policy of continuous improvement, we reserve the right to alter design and specifications without further notice.

Pre-installation instructions

The instructions in this Pre-installation Manual allow the customer and the Service Technician to prepare the installation site for the plate processor and for the installation itself.

- Never install the processor in explosive environments.
- It is the responsibility of the owner and operator/s of the processor that the installation is made in accordance with local regulations, and by engineers authorized to carry out plumbing and electrical installations.
- The manufacturer cannot be held responsible for any damage caused by incorrect installation of the processor.



Only qualified Service Technicians are allowed to unpack and install the equipment.



When preparing the installation site please take into consideration that this equipment is for restricted access locations only!



Please download the Service and User's manuals from G&J home page www.glunz-jensen.com before the installation of the processor.

Notes, cautions, and warnings !

Throughout the manual warnings, cautions, and notes are written in bold like the example below:

 **Electrical installation must conform to local regulations and guidelines.**



Symbol	Meaning	Explanation
	Note	The operator should observe and/or act according to the information in order to obtain the best possible function of the equipment.
	Caution	The operator must observe and/or act according to the information in order to avoid any mechanical or electrical damage to the equipment.
	Warning	The operator must observe and/or act according to the information in order to avoid any personal injury.

Table of contents

Part 0: Introduction	0.4
Reservations	0.4
Pre-installation instructions	0.4
Notes, cautions, and warnings !	0.5
Part 1: Transportation	1.1
When the cleaning unit arrives	1.1
Storing the cleaning unit before installation	1.1
The crate.	1.1
Checking the crate for damage.	1.2
Handling the crate	1.2
Transporting the cleaning unit	1.3
Lifting the crate	1.3
Available width for transport	1.3
Part 2: Installation requirements	2.1
General requirements	2.1
Environmental requirements	2.1
Cleaning facilities	2.1
Necessary tools and software requirements	2.1
Space requirements	2.2
Free space around the machine	2.2
Dimensions	2.3
Supply and drains.	2.4
Drains.	2.4
Electrical requirements	2.4
Main power connection.	2.4
Main power outlet	2.5
Power cable.	2.5
Electrical specifications	2.5
Installation requirements for power supply.	2.5
Fuses	2.5
Part 3: Pre-Installation Checklist	3.1

Part 1: Transportation

When the cleaning unit arrives

Storing the cleaning unit before installation

The crated cleaning unit will usually be delivered some time before the arrival of the Service Technician. In such a case you should prepare an appropriate place indoors to store the crated cleaning unit.

The crate

Below are the dimensions and weight of the crated cleaning unit:

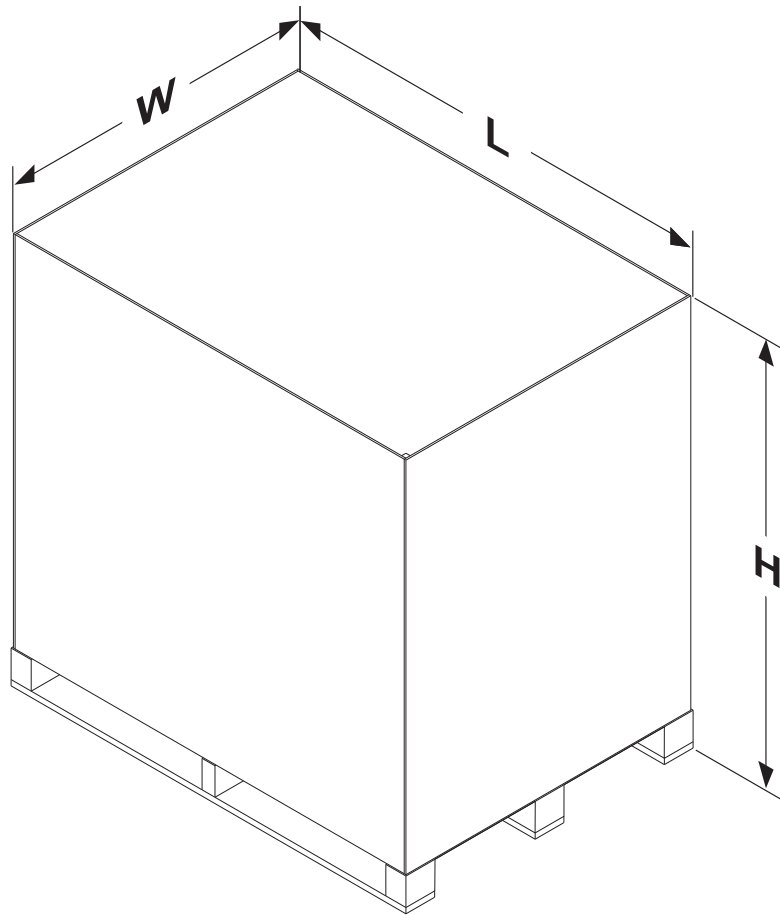

Processor Type	85	120
Length (L)	1375 mm (54.1")	1725 mm (67.9")
Width (W)	1000 mm (39.8")	1000 mm (39.8")
Height (H)	1370 mm (53.9")	1370 mm (53.9")
Weight, incl. processor w. kit	152 kg (335 lbs)	184 kg (405 lbs)

Checking the crate for damage

Check if the crate is damaged at the time of delivery. Take note of the damage before you allow the service technician to unpack the processor. Provide a detailed description or take a photograph of the damage.



Report any damage to the crate to the transport company.

Handling the crate

The icons on the crate indicate how to handle the crate during transport and storage:

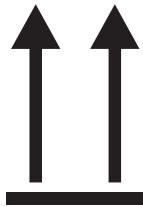

Ensure that the side indicated



Handle the crate with care.



Never expose the crate to water, or place it in a high-humidity area.

T31691

Transporting the cleaning unit

Lifting the crate

To lift the crate, at least a fork-lift truck or two persons and a hand powered pallet mover are required.

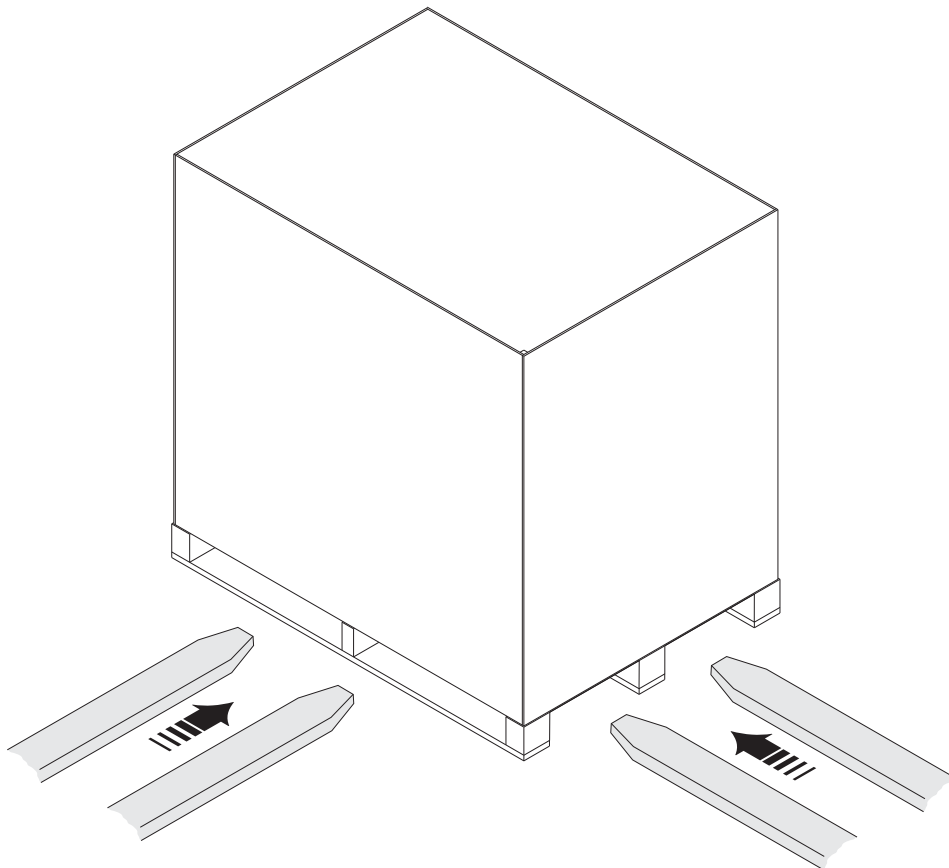

Available width for transport

Depending of the width of the door(s) through which the cleaning unit has to be transported to the installation site, the Service Technician may have to perform the actions described in the table below:

If width of the door is...

If width of the door is...	Then...
> 1000 (39.8") mm	No action is required as the crated processor can be transported immediately to the installation site.
1000 - 699 mm (39.8 - 27.5")	The Service Technician has to unpack the processor.
< 699 mm (27.5")	The Service Technician has to unpack and strip down the processor.

Part 2: Installation requirements

General requirements

Environmental requirements

Provide a heating and ventilating system capable of maintaining room temperature between 15 and 25°C (59 and 77°F) and relative humidity on max. 80%.
Heat emission from the cleaning unit is max. 1,56 kWh (5320 BTU).

Cleaning facilities

It is essential to have easy access to a sink and a water tap with hot water where rollers, guides, and brushes can be washed.

The minimum recommended size of the sink is:

85 cm processors: 100 x 40 cm (39.4 x 16")

120 cm processors: 140 x 40 cm (55.1 x 16")

Necessary tools and software requirements

- The Remote Enabling system - standard at delivery of the processor.
- PC for online connection to the processor.
- Ethernet cable (G&J part number 10064789) delivered with the processor.

Space requirements

Free space around the machine

Decide where the cleaning unit shall be placed and make sure that the free space around the machine makes servicing possible.

The recommended minimum free space around the machine is specified in the illustration below:

i For CTP On-line operation the space requirements at the front of the cleaning unit has to be decided separately.

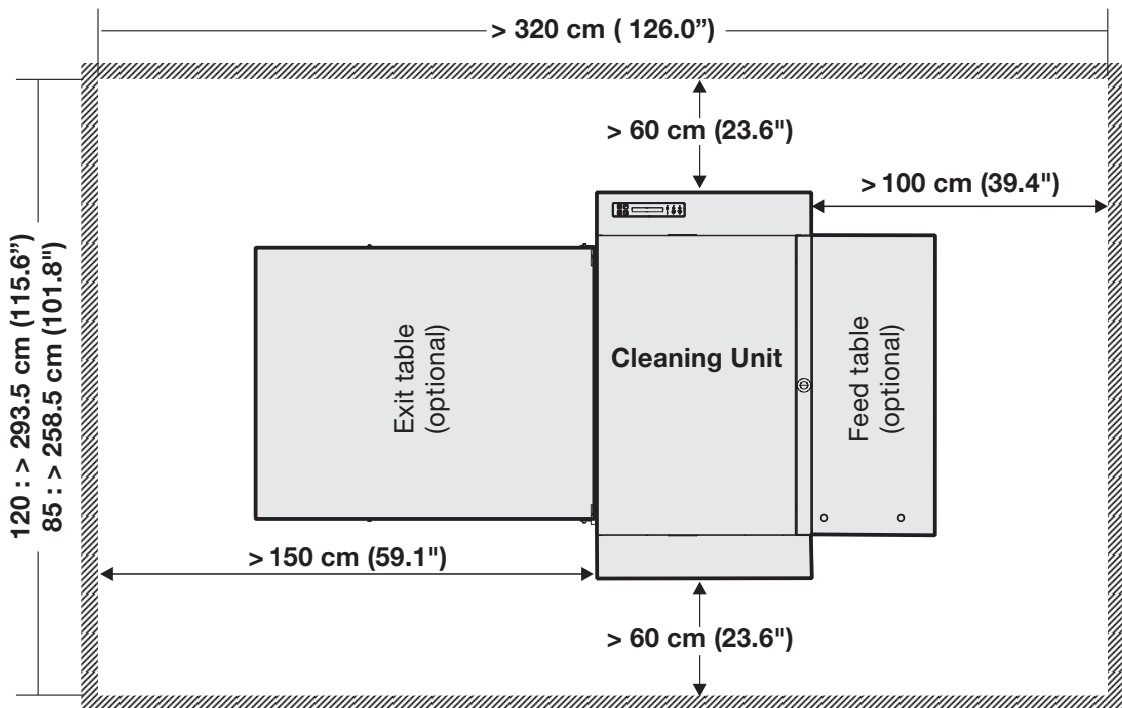

T11302

Dimensions

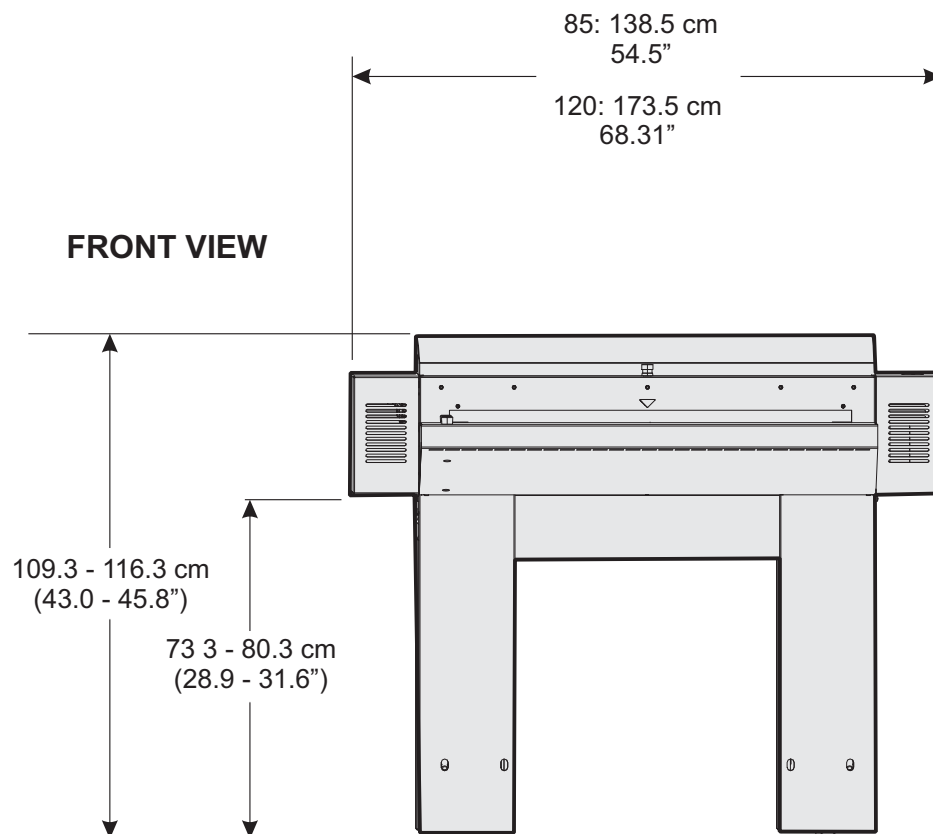
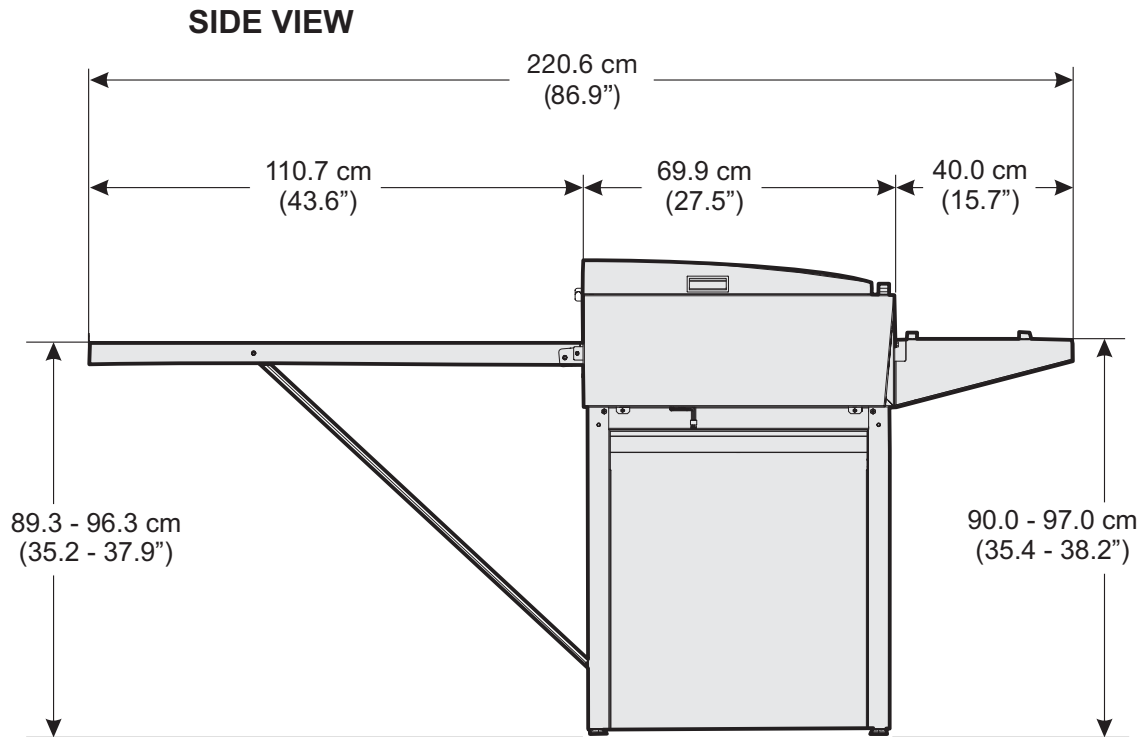

T11303

Supply and drains

Drains

- The gum is drained into a container and recirculated.



When establishing central reception systems for waste chemicals, copper or brass should not be used in the drainage system as the chemicals involved are highly corrosive. Therefore plastic or rubber is recommended. Check with the chemicals supplier for details.



Many countries have strong regulations regarding disposal of waste. Refer to the local regulations when making preparations for drains.

Electrical requirements



Electrical installation must conform to local regulations and guidelines.

Main power connection

The main power connection is made in the processor's plug located at the back of the right fender as shown in the illustration below.

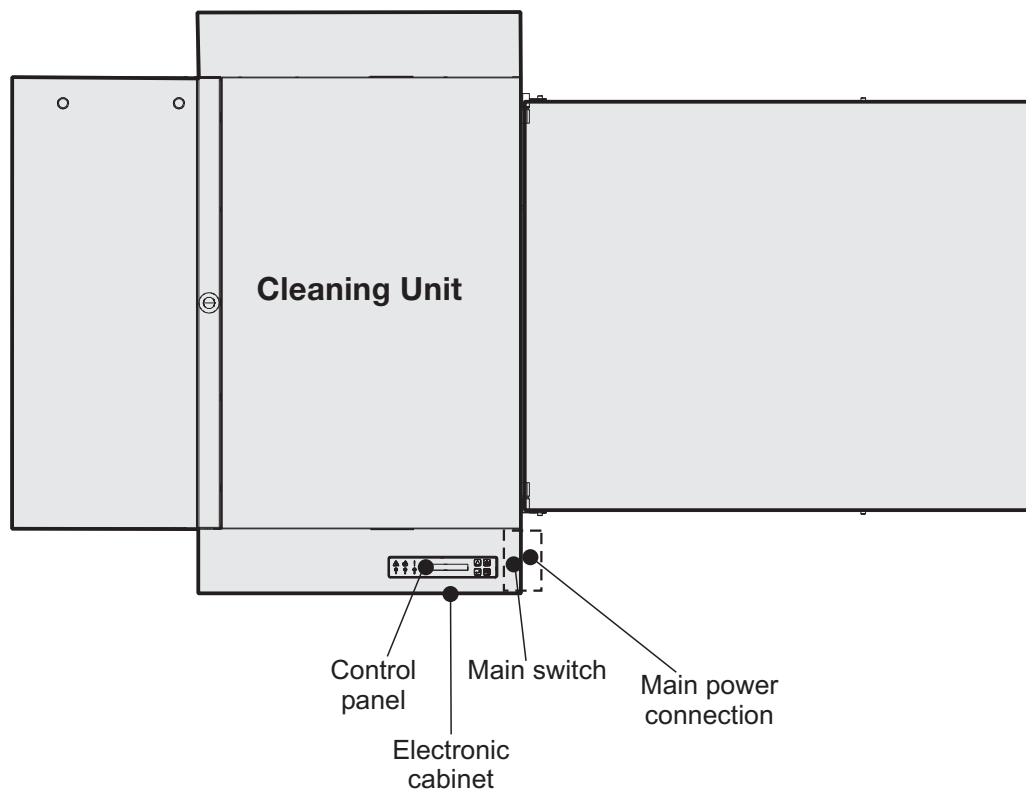

T11304

Main power outlet

Provide a main power outlet close to the installation site. The table on the next page indicates the applicable power supply types and to which processor models they apply.

Power cable

The cable for the main power connection is included for some models only. See the power supply table on the next page. The table also shows recommended power supply cables for processors delivered without cable.



When deciding what type of cable to use take into account the chemical resistance (chemicals may leak onto cable) and the mechanical resistance (operator may step onto cable).

The conductors in the power supply cable should be of copper.

Provide for additional cable protection, e.g. cable covers, if cable is exposed to heavier transport such as fork-lift trucks etc.



The processor is Class 1 equipment. Therefore, the processor must be connected to earth to avoid electrical shocks.

Please be aware of double pole/neutral fusing.

Electrical specifications

Installation requirements for power supply



Specifications on the processor's name plate is the actual input current and will thus not be identical to below mentioned.

	Supply/Fuse	Recom. cable type	85	120
EUR	Single Phase, 1W +N +PE ~230V / 1 x 10 Amps, 50 - 60 Hz	Min. 3 x 1.5 mm ² , type H07 RNF	.	.
US	Single Phase, 2W + PE 230V / 2 x 10 Amps, 50 - 60 Hz	Min. 3 x 10 AWG, type SJO	.	.
JAP	Single Phase, 2W + PE 200V / 2 x 10 Amps, 50 - 60 Hz	Min. 3 x 10 AWG, type SJO	.	.

Fuses



The fuses must have a breaking capacity of min. 100kA.

If using automatic circuit breakers make sure that they are Type D.

Part 3: Pre-Installation Checklist

Please ask the customer to answer the following questions in order to ensure a trouble-free installation of the cleaning unit:

1. Delivery of the crate and transport to the installation site **YES NO**

- A. Is there a place indoors where the packing box can be stored temporarily?
- B. Is there a hand-powered pallet mover, a fork-lift truck or any other lifting device available?
- C. Can the crate be transported directly to the installation site?
See minimum width specifications on page 7.
- D. Is it sufficient to unpack the cleaning unit before it is transported to the installation site?
See minimum width specifications on page 7.
- E. Are there other factors (stairs, elevators, corners, obstacles, etc.) which should be taken into account when transporting the crate or cleaning unit?
If so, explain:
.....
.....
.....

2. Power supply

- A. Make a note of the present supply specifications:

No. of Phases	Voltage V	Fused by Amps	
Neutral Wire?	Earth Wire?	Frequency Hz	YES NO
- B. Has a connection box been provided to connect the cleaning unit to the mains?
- C. Is the customer aware that he/she should provide (or order) all supplies (cables, fuses, etc.) necessary to connect the cleaning unit to the mains?
- D. Is there a house electrician available?
- E. Are there any known problems in the building where the cleaning unit will be installed?
If so, explain:
.....
.....
.....

3. Water supply and drain**YES NO**

- A. Capacity of air condition/ventilation adequate with regard to BTU max. 10600?
- B. Is there a large sink (with hot water) for cleaning the equipment?
- C. Will the cleaning unit be connected to a local waste treatment system?
- D. Availability of warm water for cleaning of cleaning unit?

4. Disposition of the various supplies and equipment on the installation site: