

Pre-installation Manual

CONCEPT Processor
305 DW / 405 DW / 505 DW
505 DW XP

GLUNZ & JENSEN 
DEGRAF

Pre-installation Manual

CONCEPT Processor 305 DW / 405 DW / 505 DW / 505 DW XP



T11336

Edition AA, April 2013
This book has part No 10070284

This manual is published by: **Degraf S.p.A.**
'Il Girasole' - Palazzo Donatello 8/03b
20084 Lacchiarella (MI)
Italy
Internet: www.degraf.com

Copyright © 2013 by Degraf S.p.A.

Part 0: Introduction

Reservations

- This manual was written and illustrated using the best possible information available at the time of publication.
- Any differences between this manual and the equipment reflect improvements introduced after the publication of the manual.
- Changes, technical inaccuracies and typographic errors will be corrected in subsequent editions.
- As a part of our policy of continuous improvement, we reserve the right to alter design and specifications without further notice.

Pre-installation instructions

The instructions in this Pre-installation Manual allow the customer and the Service Technician to prepare the installation site for the unit and for the installation itself.

- Never install the unit in explosive environments.
- It is the responsibility of the owner and operator/s of the unit that the installation is made in accordance with local regulations, and by engineers authorized to carry out plumbing and electrical installations.
- The manufacturer cannot be held responsible for any damage caused by incorrect installation of the unit.



Only qualified Service Technicians are allowed to unpack and install the equipment.



When preparing the installation site please take into consideration that this equipment is for restricted access locations only!

Notes, cautions, and warnings !

Throughout the manual warnings, cautions, and notes are written in bold like the example below:



Electrical installation must conform to local regulations and guidelines.

Symbol	Meaning	Explanation
	Note	The operator should observe and/or act according to the information in order to obtain the best possible function of the equipment.
	Caution	The operator must observe and/or act according to the information in order to avoid any mechanical or electrical damage to the equipment.
	Warning	The operator must observe and/or act according to the information in order to avoid any personal injury.

Table of contents

Part 0: Introduction	0-3
Reservations	0-3
Pre-installation instructions	0-3
Notes, cautions, and warnings !	0-3
Part 1: Transportation	1-1
When the unit arrives	1-1
Storing the unit before installation	1-1
The crate	1-1
Checking the crate for damage.	1-1
Handling the crate	1-1
Dimensions and weight.	1-2
Transporting the unit.	1-3
Lifting the crate	1-3
Available width for transport	1-3
Part 2: Installation requirements	2-1
Environmental requirements	2-1
Accessories needed for the connections	2-1
Installation kit	2-1
Space requirements	2-2
Free space around the unit	2-2
Unit dimensions and connection locations.	2-4
Compressed air supply	2-8
Solvent connection	2-8
Exhaust.	2-8
Electrical requirements	2-9
Main power connection.	2-9
Main power outlet	2-9
Power supply cable	2-9
Electrical specifications.	2-10
Fuses	2-10
Power consumption	2-10
Part 3: Pre-installation checklist	3-1

Part 1: Transportation

When the unit arrives

Storing the unit before installation

The crated unit will usually be delivered some time before the arrival of the Service Technician. In which case you should prepare an appropriate place indoors to store the crated unit.

The crate

Checking the crate for damage

Check if the crate is damaged at the time of delivery. Take note of the damage before you allow the Service Technician to unpack the unit. Provide a detailed description or take a photograph of the damage.

 Report any damage to the crate to the transport company.

Handling the crate

The icons on the crate indicate how to handle the crate during transport and storage:



Ensure that the side indicated by the arrows is always up



Handle the crate with care.



Never expose the crate to water, or place it in a high-humidity area.



Do not stack the crates.



Do not tilt the crate.

Dimensions and weight

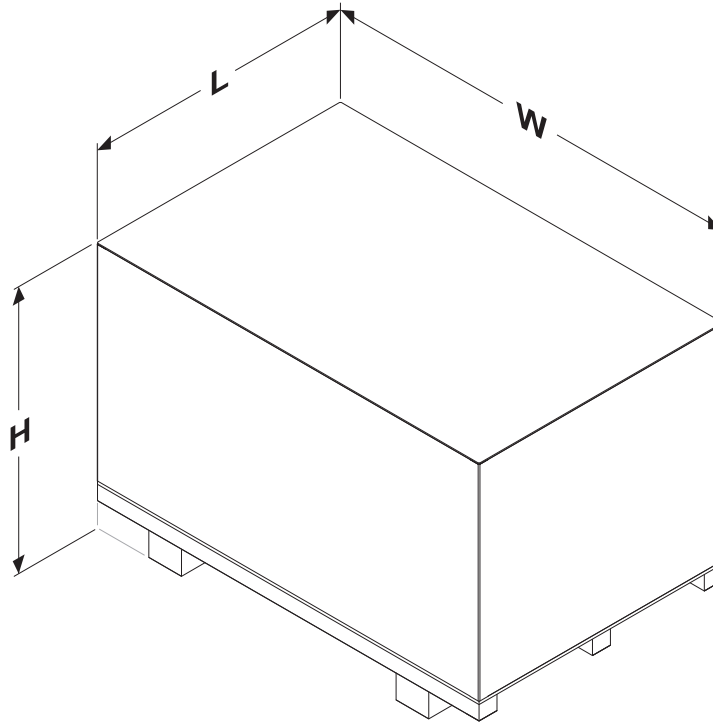

T32328

	305 DW	405 DW	505 DW	505 DW XP
Width (W)	1950 mm (76.8")	2220 mm (87.4")	2400 mm (94.5")	2400 mm (94.5")
Length (L)	2900 mm (114.2")	2780 mm (109.5")	3000 mm (118.1")	4300 mm (169.3")
Height (H)	1750 mm (68.9")	1750 mm (68.9")	2000 mm (78.7")	1750 mm (68.9")
Weight, crated (\pm 5%)	approx. 1400 kg (3086 lb)	approx. 1690 kg (3726 lb)	approx. 1650 kg (3638 lb)	approx. 2180 kg (4806 lb)
Weight, unit	approx. 1070 kg (2359 lb)	approx. 1290 kg (2844 lb)	approx. 1340 kg (2954 lb)	approx. 1730 kg (3814 lb)

Transporting the unit

Lifting the crate

The unit is supplied in a wooden crate. The unit is very heavy equipment. To lift the crate a fork-lift truck is required.

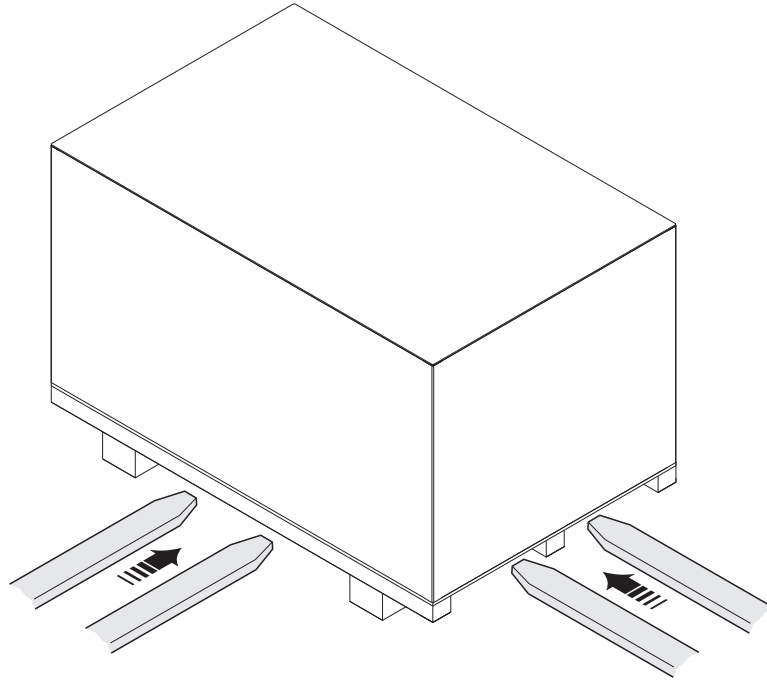

T32327

Available width for transport

Depending on the width of the door(s) through which the unit has to be transported to the installation site, the Service Technician may have to perform the actions described in the table below:

If width of the door is...				Then...
305 DW	405 DW	505 DW	505 DW XP	
> 1970 mm (77.6")	> 2240 mm (88.2")	> 2420 mm (95.3")	> 2420 mm (95.3")	No action is required as the crated unit can be transported immediately to the installation site.
> 1700 mm (66.9")	> 1980 mm (78")	> 2100 mm (82.7")	> 2170 mm (85.4")	The Service Technician has to unpack the unit.

Part 2: Installation requirements



This unit must be installed in restricted access locations only.

Environmental requirements

Provide a heating and ventilating system capable of maintaining room temperature between 17 and 25°C (63 and 77°F) and relative humidity between 40 and 60%.

For heat emission see “Power consumption” on the page 2-10.

Accessories needed for the connections

Compressed air supply	hose, ø6
Exhaust	hose, ø140
Solvent	solvent resistant hose, ø20
Power supply	see page 2-10 for recommended cable type

Installation kit

Installation kit is included with the unit. It comprise the parts necessary to make the installation. See Service Manual for installation part list.



The processor is delivered with the necessary parts to have both washout solvent and pre-washing solvent drains connected together.

Space requirements

Free space around the unit

Decide where the unit shall be placed and make sure that the free space around the machine makes servicing possible.

The recommended minimum free space around the unit is:

- 1200 mm (47.2") in front and at the back of the unit,
- 750 mm (29.5") on the sides of the unit.

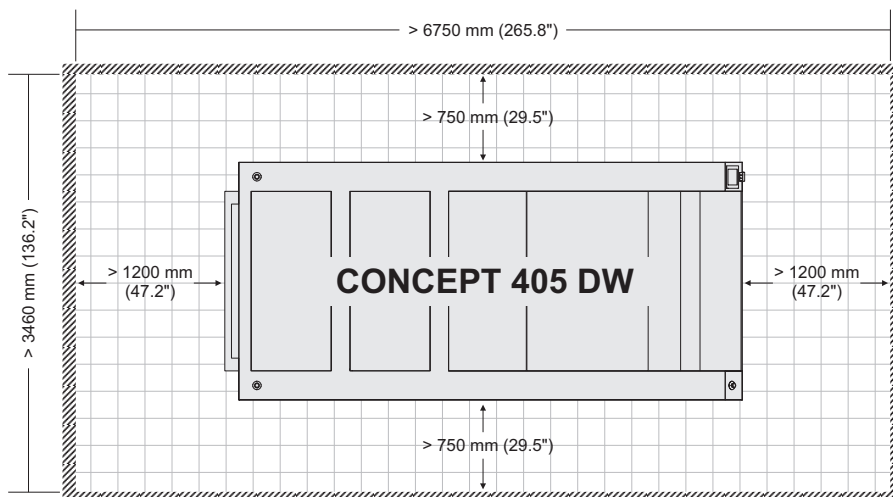
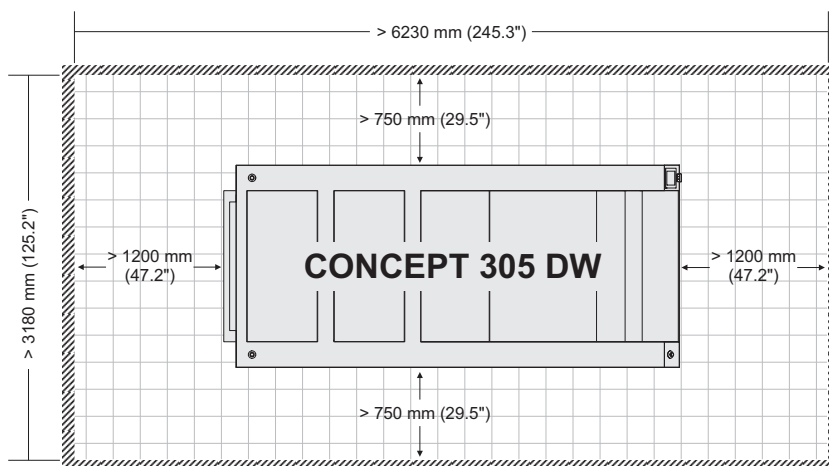

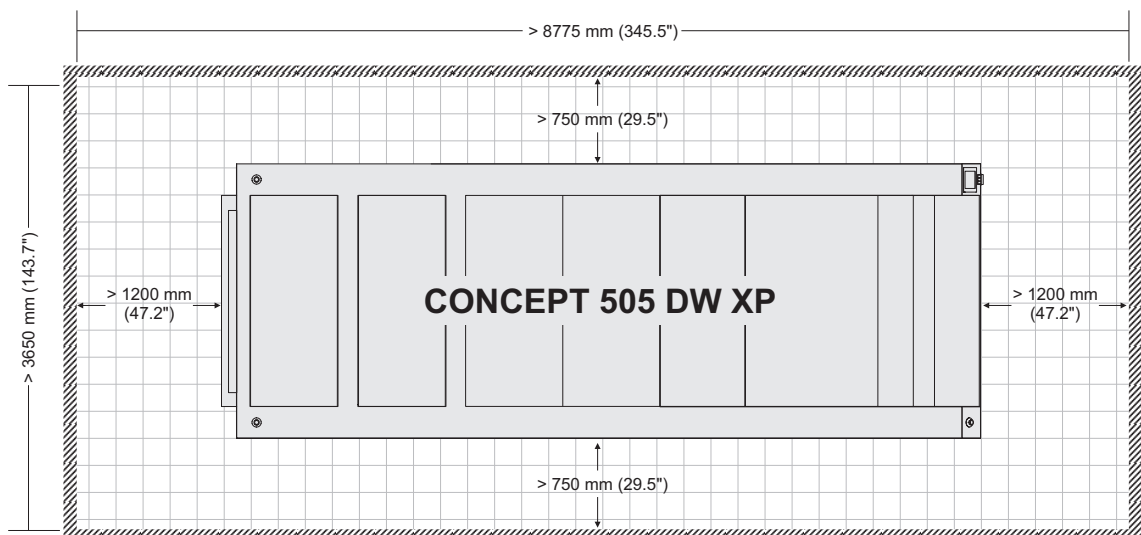
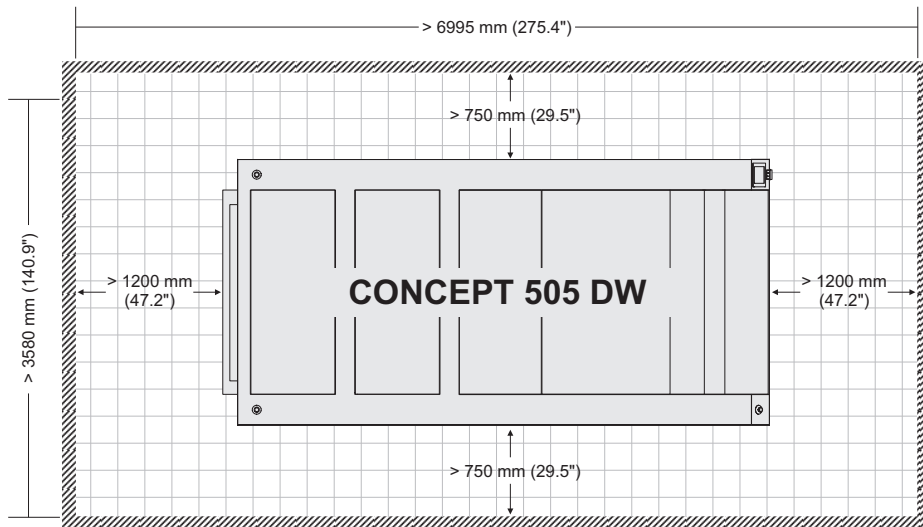

Unit dimensions and connection locations

CONCEPT 305 DW

Side view

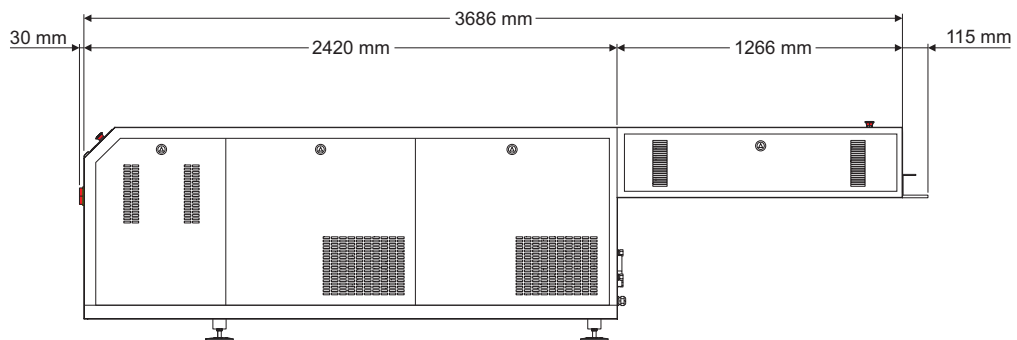

Rear view

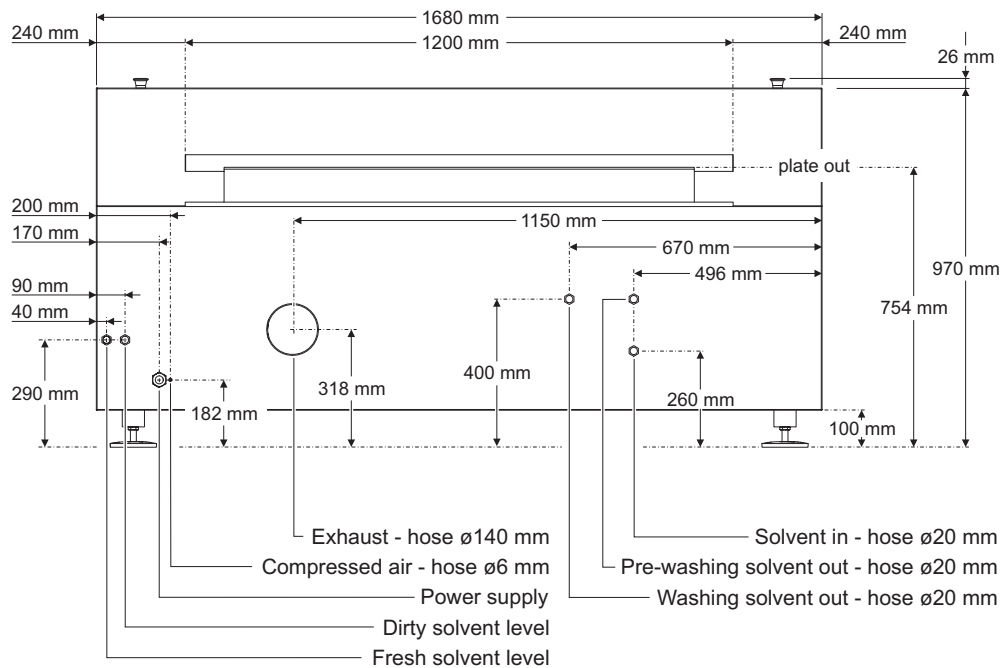

T11337

CONCEPT 505 DW

Side view

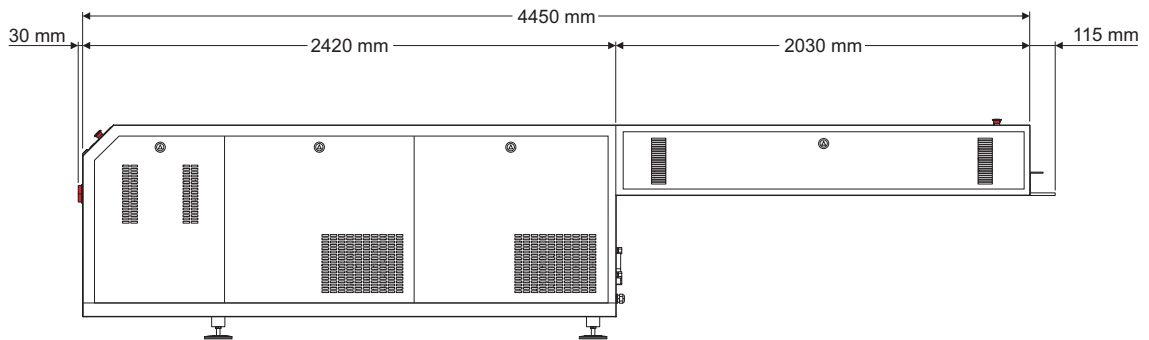

Rear view

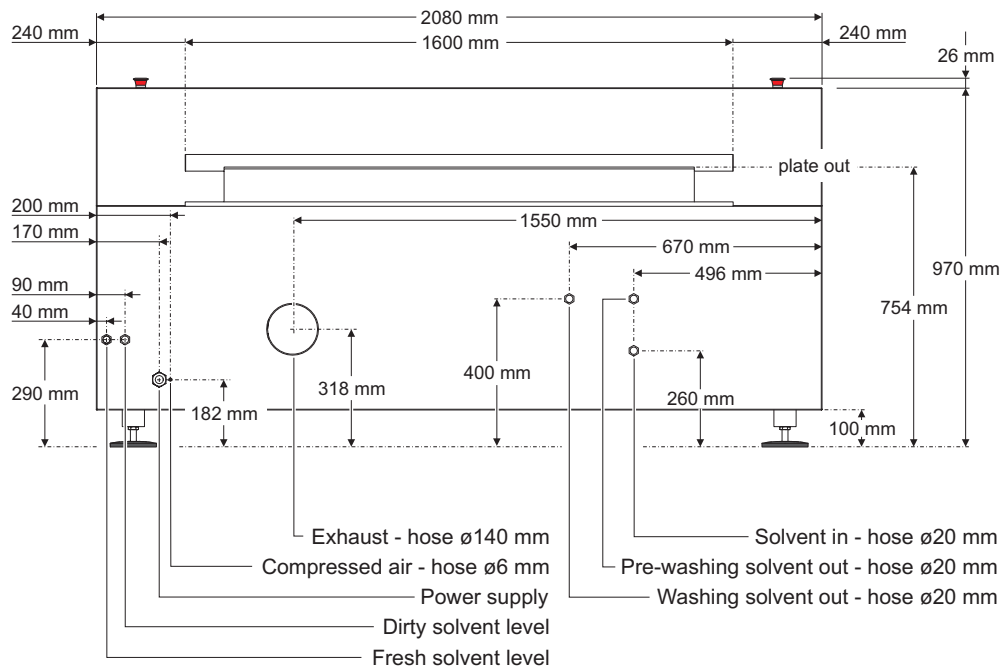

T11339

CONCEPT 505 DW XP

Side view

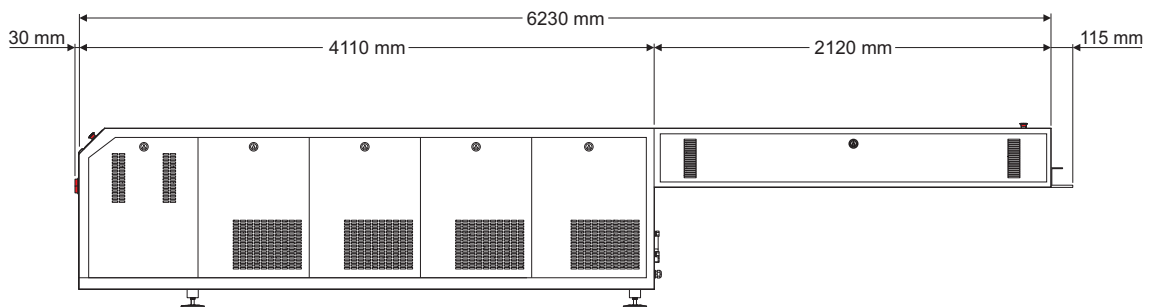

Rear view

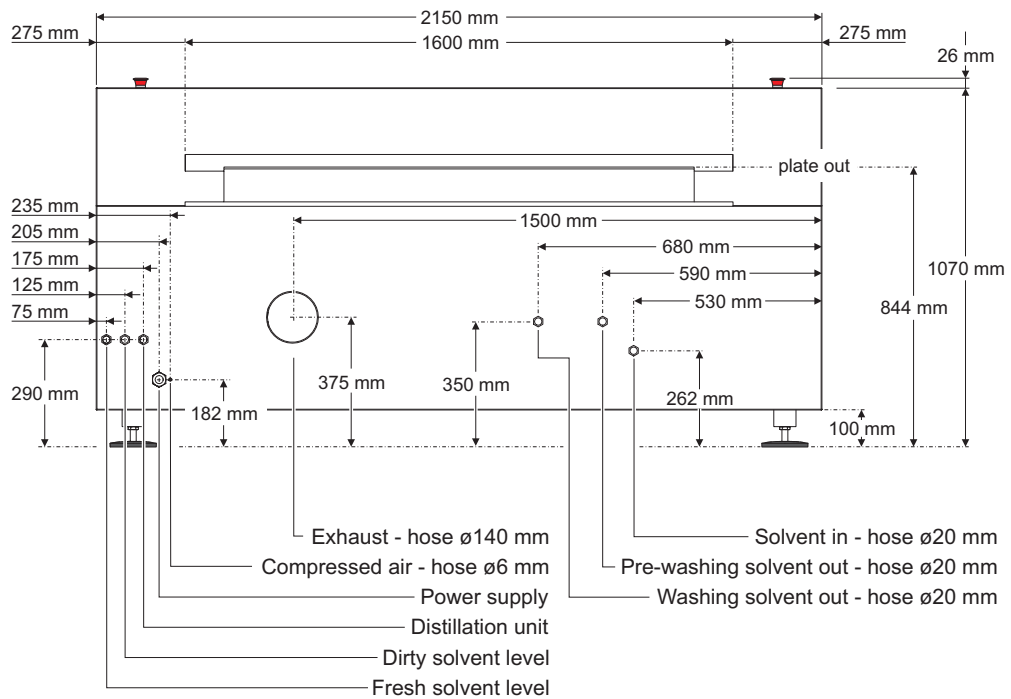

T11340

Compressed air supply

The compressed air supply connection is located on the rear side of the unit. The supply air pressure must be min. **6 bar (87 psi)**.

Solvent connection

If the solvent barrels are more than 5 meters from the processor and the piping is lifted higher than the solvent tanks, it is recommended to mount a nonreturn valve at the barrels to prevent backlash of solvent/air in the hoses during process.

In case of need to turn off the solvent supply to the processor, it is recommended to install handvalves in the end of the solvent installation.



Never lead solvent out - hose into a drain, as most solvents are strong pollutants. It is also illegal to empty these types of chemicals into the public sewer system.

Under all circumstances local regulations applying to the treatment of (chemical) waste must be followed strictly.

Exhaust

All the exhaust must be connected to the appropriate location (directly to the outside or to the building exhaust installation). Make sure that the airflow is correct. Minimum exhaust of the machine is 600 m³/h.

Electrical requirements



Electrical installation must conform to local regulations and guidelines.

Main power connection

The main power connection must be made to the main connector located at the back of the unit.

Main power outlet

Provide a main power outlet close to the installation site. The table on the next page indicates the applicable power supply types and to which unit model they apply.

Power supply cable

The cable/plug required for main power connection is not delivered with the unit. The power supply table on the next page shows recommended power supply cable for unit.



The conductors in the power supply cable must be of copper.

When deciding what type of cable to use take into account the mechanical resistance (operator may step onto cable).

Provide for additional cable protection, e.g. cable covers, if cable is exposed to heavier transport such as fork-lift trucks etc.



The unit is Class 1 equipment. Therefore, the unit must be connected to earth to avoid electrical shocks.

Please be aware of double pole/neutral fusing.

Electrical specifications

Installation requirements for power supply

	Supply / fuse	Recom. cable type	305 DW	405 DW	505 DW	505 DW XP
EUR	3Ph + N + PE, 400 VAC 3 x 13 Amps, 50-60 Hz	Min. 5 x 6 mm ² , type H07RNF	●	●	●	
	3Ph + N + PE, 400 VAC 3 x 16 Amps, 50-60 Hz	Min. 5 x 6 mm ² , type H07RNF				●
US	3Ph + PE, 230 VAC 3 x 24 Amps, 50-60 Hz	Min. 4 x 10 AWG, type SJO or better	●	●	●	
	3Ph + PE, 230 VAC 3 x 28 Amps, 50-60 Hz	Min. 4 x 10 AWG, type SJO or better				●
All	Voltage tolerance ± 10%					

Fuses



The fuses must have a breaking capacity of min. 100kA.
If using automatic circuit breakers make sure that they are Type D.

Power consumption

	Power consumption at ...	305 DW	405 DW	505 DW	505 DW XP
All	230/400 VAC operation: approx.	8.5 kW	8.5 kW	8.5 kW	10 kW

Part 3: Pre-installation checklist

Please ask the customer to answer the following questions in order to ensure a trouble-free installation of the unit:

- | 1. Delivery of the crate and transport to the installation site | YES | NO |
|--|--------------------------|--------------------------|
| A. Is there a place indoor where the crated unit can be stored temporarily? | <input type="checkbox"/> | <input type="checkbox"/> |
| B. Is there a hand-powered pallet mover, a fork-lift truck or any other lifting device available? | <input type="checkbox"/> | <input type="checkbox"/> |
| C. Can the crate be transported directly to the installation site?
<i>See minimum width specifications on page 1-3.</i> | <input type="checkbox"/> | <input type="checkbox"/> |
| D. Is it sufficient to unpack the unit before it is transported to the installation site? <i>See minimum width specifications on page 1-3.</i> | <input type="checkbox"/> | <input type="checkbox"/> |
| E. Are there other factors (stairs, elevators, corners, obstacles, etc.) which should be taken into account when transporting the crate or unit? | <input type="checkbox"/> | <input type="checkbox"/> |
| If so, explain: | | |
| | | |
| | | |
| | | |

2. Power supply

- | | | |
|---|--------------------------|--------------------------|
| A. Make a note of the present supply specifications: | | |
| No. of Phases | Voltage V | Fused by Amps |
| Neutral Wire? | Earth Wire? | Frequency Hz |
| | YES | NO |
| B. Has a connection box been provided to connect the unit to the mains? | <input type="checkbox"/> | <input type="checkbox"/> |
| C. Is the customer aware that he/she should provide (or order) all supplies (cables, fuses, etc.) necessary to connect the unit to the mains? | <input type="checkbox"/> | <input type="checkbox"/> |
| D. Is there a house electrician available? | <input type="checkbox"/> | <input type="checkbox"/> |
| E. Are there any known problems in the building where the unit will be installed? | <input type="checkbox"/> | <input type="checkbox"/> |
| If so, explain: | | |
| | | |
| | | |
| | | |
| | | |

3. Connections**YES NO**

- | | | |
|---|--------------------------|--------------------------|
| A. Capacity of air condition/ventilation adequate with regard to power consumption as specified on page 2-10? | <input type="checkbox"/> | <input type="checkbox"/> |
| B. Is there a compressed air supply available? | <input type="checkbox"/> | <input type="checkbox"/> |
| C. Can a hose (6 mm diameter) be connected to the compressed air supply? | <input type="checkbox"/> | <input type="checkbox"/> |
| D. Is the supply air pressure 6 bar (87 psi)? | <input type="checkbox"/> | <input type="checkbox"/> |
| E. Is there a exhaust system available? | <input type="checkbox"/> | <input type="checkbox"/> |
| F. Can a hose (140 mm diameter) be connected to the exhaust system? | <input type="checkbox"/> | <input type="checkbox"/> |
| G. Is there a solvent installation available (diameter 20 mm)? | <input type="checkbox"/> | <input type="checkbox"/> |
| H. Availability of warm water for cleaning of unit? | <input type="checkbox"/> | <input type="checkbox"/> |

4. Disposition of the various supplies and equipment on the installation site: