



Pre-installation Guide

Concept 301 LF/401 LF/501 LF

▶ **IMPORTANT**

Please follow the instructions in this guide when preparing the installation site prior to arrival and installation of the equipment.

GLUNZ & JENSEN 

May 21st, 2018
Edition CA, Part No 10074759
English (en-us) Original version

(Blank)

About this manual

This manual applies to the Light Finisher **Concept 301 LF / 401 LF / 501 LF**.

This manual is published by:

Glunz & Jensen A/S

Lindholm Havnevej 29

5800 Nyborg

Denmark

Phone: +45 57 68 81 81

E-mail: gjhq@glunz-jensen.com

Internet: www.glunz-jensen.com

Copyright © May, 2018 by Glunz & Jensen A/S

Table of Contents

About this manual	3
Table of Contents	4
Introduction	5
Reservations	5
Introduction	5
Notes, Cautions and Warnings!	5
Transportation	7
When the equipment arrives	7
Storing of the equipment prior to the installation	7
The crate	7
Crate Dimensions	7
Concept	7
Weight	8
Checking the crate for damage	8
Handling the crate	8
Lifting the crate	9
Required width of passage and doorways	10
Installation requirements	11
Heating and ventilation	11
Installation kit	11
Space requirements	12
Free space around the equipment	12
Dimensions and connections	13
Exhaust connection	14
Electrical requirements	15
Main power outlet	15
Power cable	15
Electrical specifications	16
Power supply requirements	16
Power consumption	16
Concept	16
Checklist	17

Introduction

Reservations



- This manual was written and illustrated using the best possible information available at the time of publication.
- Any differences between this manual and the equipment reflect improvements introduced after the publication of the manual.
- Changes, technical inaccuracies and typographic errors will be corrected in subsequent editions.
- As a part of our policy of continuous improvement, we reserve the right to alter design and specifications without further notice.

Introduction

The instructions in this Pre-installation Guide help the customer and the Service Technician to prepare the installation site for the arrival and installation of the equipment.

Notes, Cautions and Warnings!

Notes, cautions, and warnings in this manual are used and categorized as described below:

Symbol	Meaning	Explanation
	NOTE	The operator should observe and/or act according to the information in order to obtain the best possible function of the equipment.
	CAUTION	The operator must observe and/or act according to the information in order to avoid any mechanical or electrical damage to the equipment.
	WARNING	The operator must observe and/or act according to the information in order to avoid any personal injury.



(blank page)

Transportation

When the equipment arrives

Storing of the equipment prior to the installation

The equipment will usually be delivered some time before the arrival of the service technician. Provide for an appropriate place indoor to store the crated equipment until the service technician arrives.

The crate

Crate Dimensions

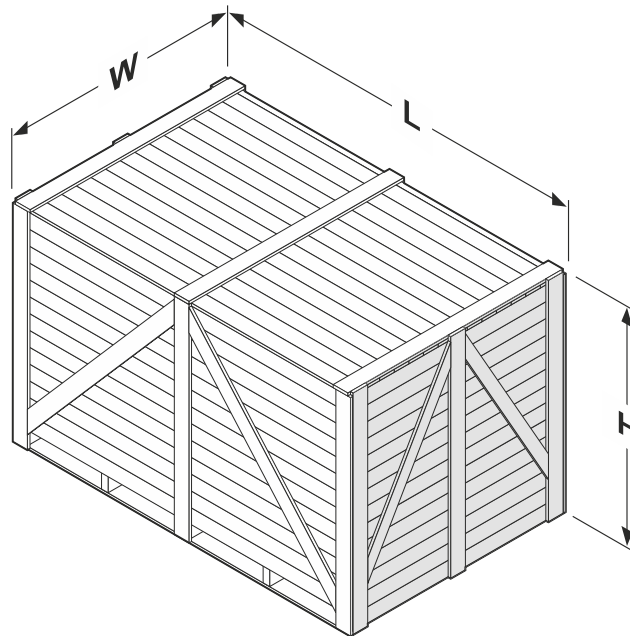

Concept

	301 LF	401 LF	501 LF
Length (L)	1638 mm (64.5")	1638 mm (64.5")	1938 mm (76.3")
Width (W)	1910 mm (75.2")	2250 mm (88.6")	2670 mm (105.1")
Height (H)	1117 mm (44")	1117 mm (44")	1117 mm (44")

Weight

	301 LF	401 LF	501 LF
With crate	391 kg (862 lbs)	650 kg (1433 lbs)	750 kg (1654 lbs)
Without crate	220 kg (485 lbs)	320 kg (706 lbs)	400 kg (882 lbs)

Checking the crate for damage

Check if the crate is damaged on delivery at the customer's address. Make notes of any damages, before opening the crate. Provide a detailed description and take a photograph of the damage.

Report any damage of the crate to the shipping company and notify the insurance agent, if appropriate, before the mishandled package is opened.

Handling the crate

The icons on the crate indicate how to handle the crate during transport and storage:



Ensure that the side indicated by the arrows is always up.



Handle the crate with care



Never expose the crate to water, or place it in a high-humidity area.



Do not stack the crates.



Do not tilt the crate.

Lifting the crate

The equipment is supplied in a wooden crate on a pallet.

A fork-lift truck is required for lifting the crate on arrival and for lifting the equipment off the pallet.



WARNING: The equipment is very heavy equipment.

It is only possible to lift the equipment off the pallet using a forklift truck or a pallet mover.



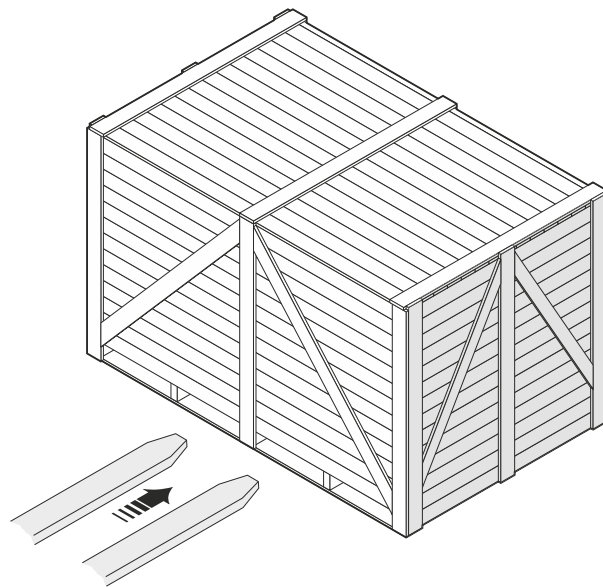

CAUTION: Make sure to provide a forklift designed and adequate for lifting a crate of the size and weight as specified in this manual.



Required width of passage and doorways

Depending on the width of the passage- and doorways through which the equipment has to be transported to the installation site, the service technician may have to perform the actions described in the table below:

If width of the doorway is ...	301 LF	401 LF	501 LF	Then ...
More than	1700 mm (66.9")	2100 mm (82.7")	2550 mm (100.4)	The crated equipment can be transported immediately to the installation site.  CAUTION: May require machine moving skates suitable for transport of very heavy equipment. Please refer to "Weight" on page 8.
Less than but more than	1700 mm (66.9") 1550 mm (61.0")	2100 mm (82.7") 1550 mm (61.0")	2550 mm (100.4) 1900 mm (74.8")	The Service Technician has to unpack the equipment.  CAUTION: May require machine moving skates suitable for transport of very heavy equipment. Please refer to "Weight" on page 8.

Installation requirements



WARNING: The equipment must be installed in restricted access locations only.



NOTE: Check the delivery route to the installation location for necessary clearance and remove all obstructions.

Heating and ventilation

Provide a heat and ventilation system capable of maintaining room temperature between 17°C (63°F) and 28°C (82°F) and a relative humidity (non condensing) of min. 20 % and max. 80%.

For heat emission see "Power consumption" on page 16.

Installation kit

Installation kit is included with the equipment. It comprise the parts necessary to make the installation.

Space requirements

Free space around the equipment

Decide for a proper installation site for the equipment and make sure that the free space around the equipment makes servicing possible.

The recommended minimum free space around the equipment is specified in the next illustration.

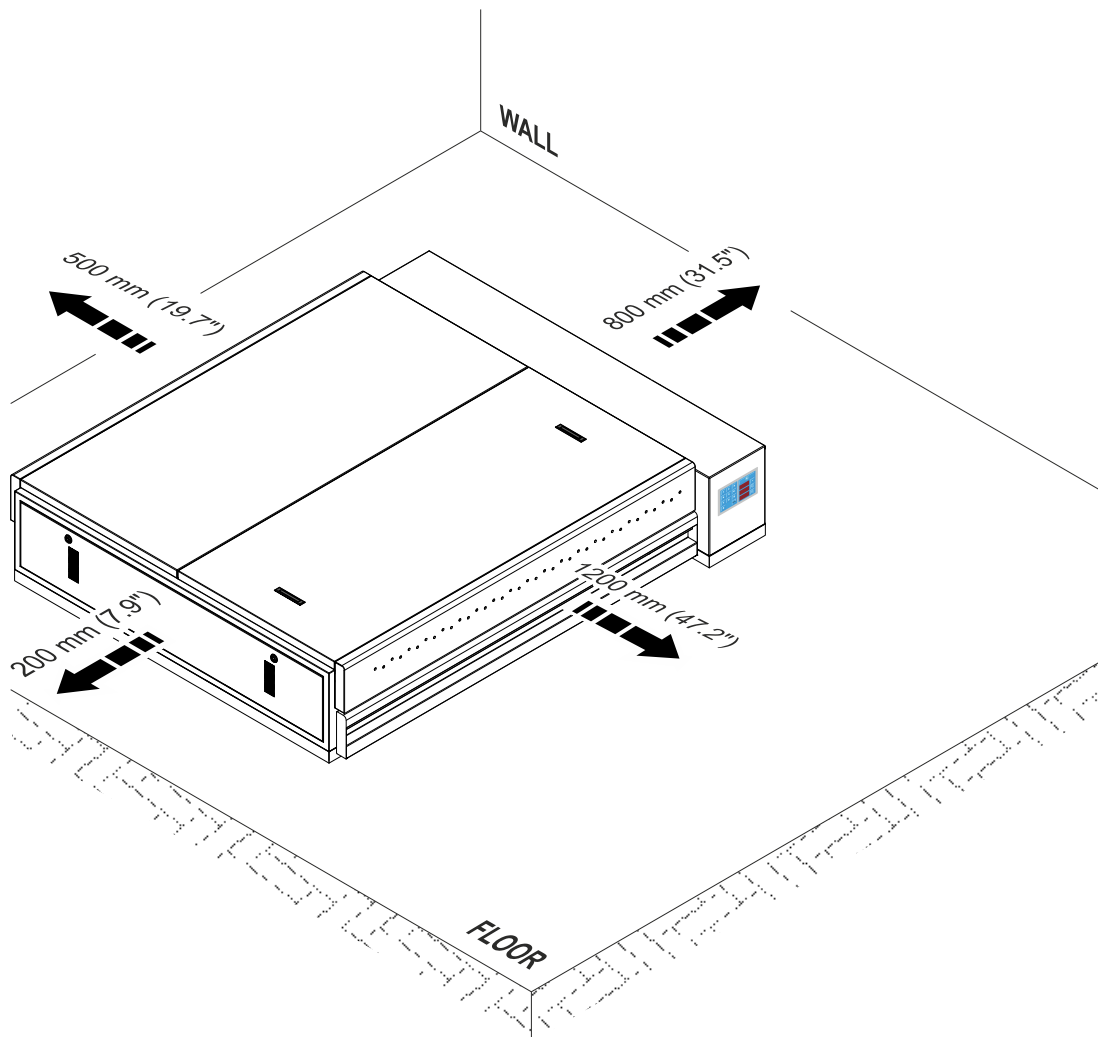

Dimensions and connections

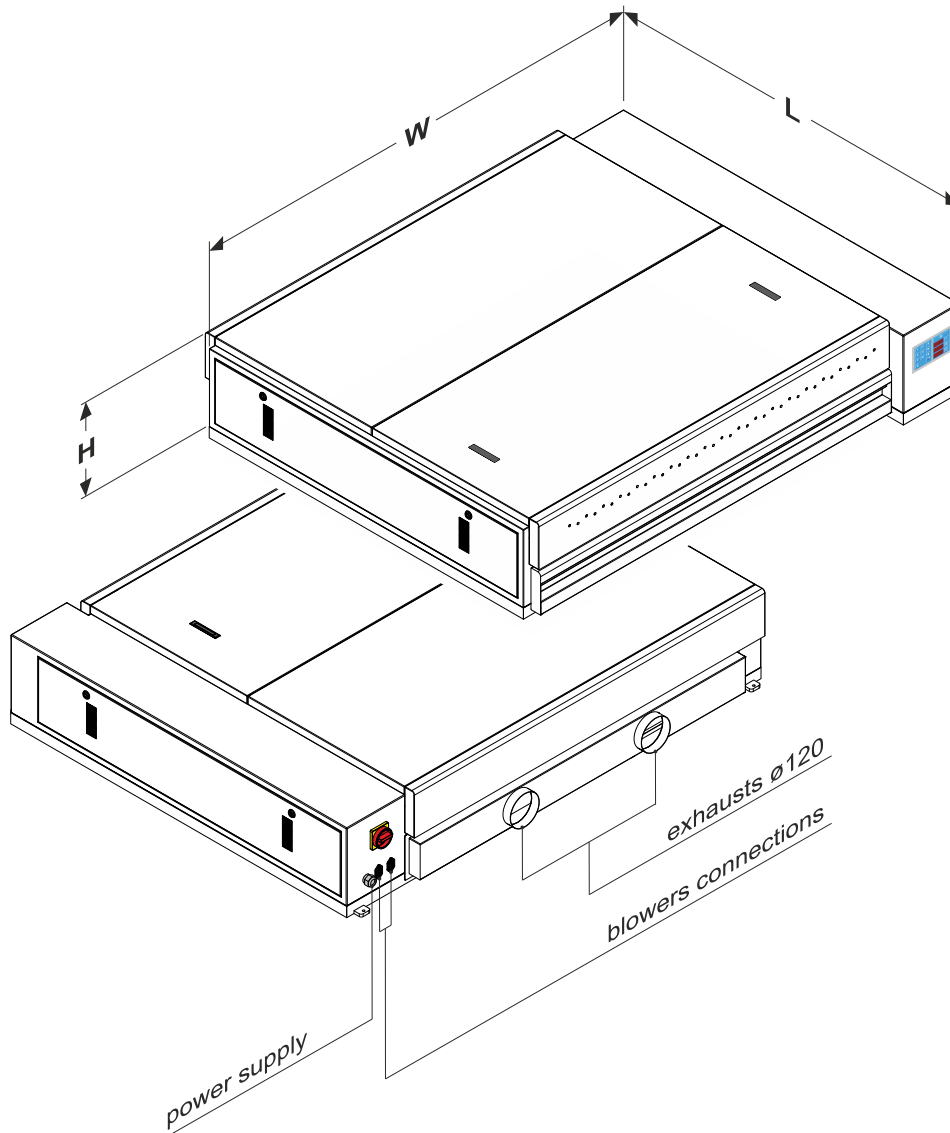

	301 LF	401 LF	501 LF
Width (W)	1735 mm (68.3")	2080 mm (81.9")	2500 mm (98.4")
Length (L)	1470 mm (57.9")	1470 mm (57.9")	1768 mm (69.6")
Height (H)	355 mm (14.0")	355 mm (14.0")	355 mm (14.0")

Exhaust connection

Light finisher exhaust must be connected to the appropriate and separate location (directly to the outside or to the building exhaust installation).



WARNING: Do not connect the dryer and light finisher exhausts together as the mixing of vapors could create explosive fumes emission depending of the solvent used to wash the plates.

Make sure that the airflow is correct and minimum exhaust capacity is according to the Exhaust specification table.

	301 LF	401 LF	501 LF
Light finisher , min.	2 × 400 m ³ /h (235 ft ³ /min)	2 × 800 m ³ /h (470 ft ³ /min)	2 × 1000 m ³ /h (590 ft ³ /min)

Electrical requirements

 **WARNING:** Electrical installation must conform to local regulations and guidelines.

Main power outlet

Provide an mains power-outlet with an electrical plug lockout close to the installation site. The table showing "Power supply requirements" on the next page indicates the applicable power supply types.

Power cable

 **NOTE:** The cable for the main power connection is included with the equipment.

 **WARNING:** The equipment is Class 1 equipment. Therefore, the equipment must be connected to earth to avoid electrical shocks.

Please be aware of double pole/neutral fusing.

 **CAUTION:**

The conductors in the power supply cable should be of copper.

Provide for additional cable protection, e.g. cable covers, if cable is exposed to heavier transport such as fork-lift trucks etc.

Electrical specifications

Power supply requirements



CAUTION: The requirements below are specifications for preparing the installation protection. The fuses/circuit breakers must be prepared according to local regulations, and with adequate capacity as specified here. The circuit breakers must be suitable for inventor operation.



NOTE: Specifications on the equipment's name plate is the actual input current and will thus not be identical to below mentioned.

	Supply *	Fuses and cables types		
		301 LF	401 LF	501 LF
EUR	3W + N + PE, 400 VAC, 50/60 Hz	Fused by 3 × 5 Amps Cable type: Min. 5 × 2.5 mm ² , type H07 RNF	Fused by 3 × 6 Amps Cable type: Min. 5 × 2.5 mm ² , type H07 RNF	Fused by 3 × 8.5 Amps Cable type: Min. 5 × 2.5 mm ² , type H07 RNF
US	3W + PE, 230 VAC, 50/60 Hz	Fused by 3 × 9 Amps Cable type: Min. 4 × 10 AWG, type S, SJ, SJO or SJT	Fused by 3 × 11 Amps Cable type: Min. 4 × 10 AWG, type S, SJ, SJO or SJT	Fused by 3 × 15 Amps Cable type: Min. 4 × 10 AWG, type S, SJ, SJO or SJT

*) Voltage tolerance ± 10%



NOTE: The power cable(s) must be in accordance with local regulations.



WARNING: Please be aware of double pole/neutral fusing.



CAUTION: The fuses must have a breaking capacity of min. 100 kA.

Power consumption

Concept

	301 LF	401 LF	501 LF
In operate by 230 VAC (±10%) per phase, max.	3200 W	4000 W	5500 W

Checklist

Please check the following conditions in order to ensure a trouble-free installation of the equipment:

- | 1. | Delivery of the crate and transport to the installation site | YES | NO |
|-------|---|------------|-----------|
| A. | Is there a place indoor where the crated equipment can be stored temporarily? | o | o |
| B. | Is there a hand-powered pallet mover, a fork-lift truck or any other lifting device available? Please refer to "Lifting the crate" on page 1 for required lifting equipment. | o | o |
| C. | Can the crate be transported directly to the installation site? See "Required width of passage and doorways" on page 10.. | o | o |
| D. | Is it necessary to unpack the equipment before it is transported to the installation site? See "Required width of passage and doorways" on page 10.. | o | o |
| E. | Are there other factors (stairs, elevators, corners, obstacles, etc.) which should be taken into account when transporting the equipment?
If YES, please describe: | o | o |
| <hr/> | | | |
| 2. | Power supply | YES | NO |
| A. | Make a note of the present supply specifications:

Number of phases: _____ Neutral wire? o
Voltage (V): _____ Earth wire? o
Fused by (Amps): _____
Frequency (Hz): _____ | | |
| B. | Has a connection box been provided to connect the equipment to the mains? | o | o |
| C. | Has the customer been asked to provide for all supplies (cables, fuses, etc.) necessary to connect the equipment to the mains? | o | o |
| D. | Is there a house electrician available? | o | o |
| E. | Are there any known problems in the building where the equipment will be installed?
If YES, please describe which: | o | o |
| <hr/> | | | |
| 3. | Connections | YES | NO |
| A. | Is air condition/ventilation available according to the requirements as described in chapter "Exhaust connection" on page 14.? | o | o |