

Pre-installation Manual



MS 1320/1700

Pre-installation Manual

MS 1320/1700

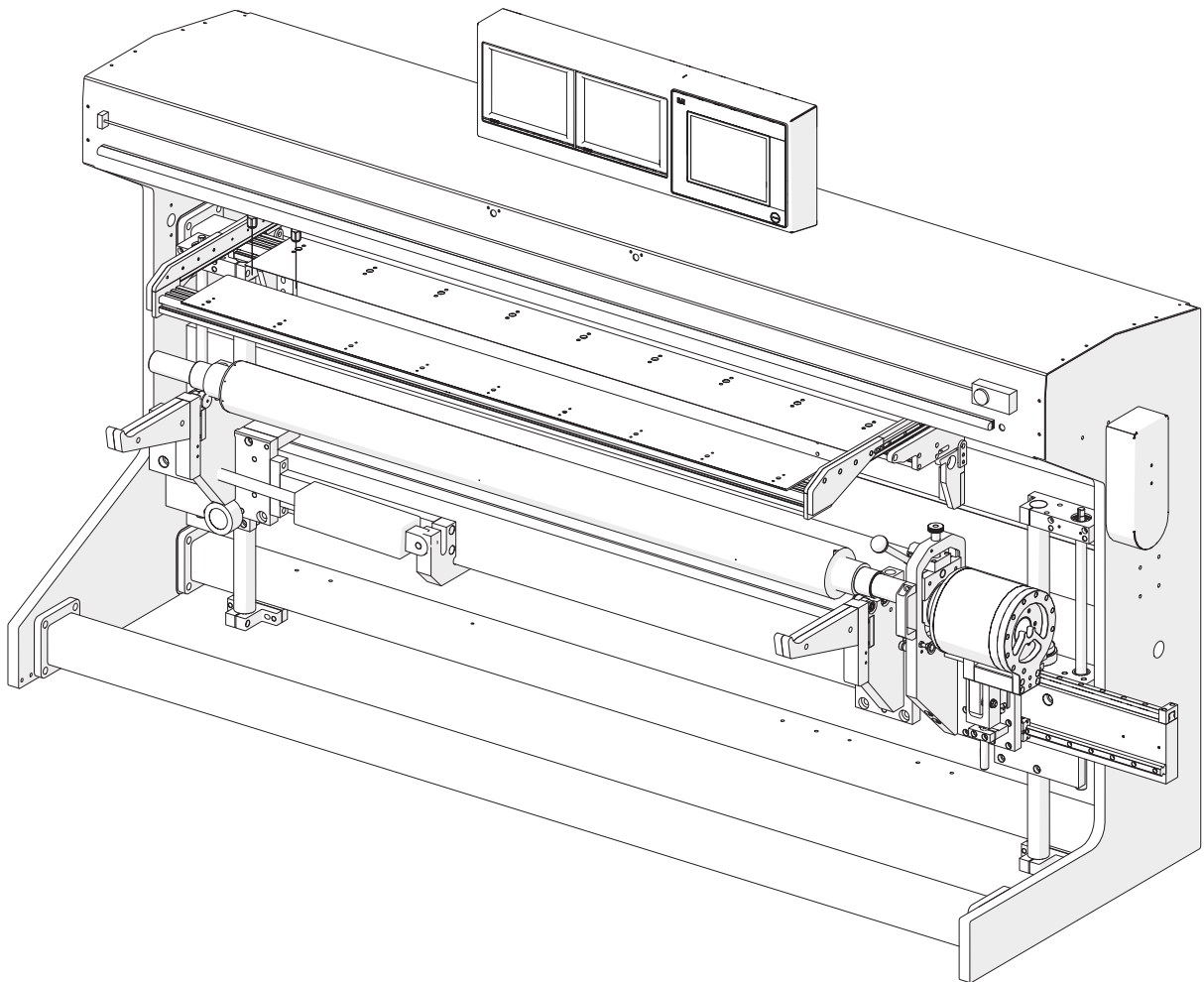

Edition AA, June 2014
This book has part no 10076645

This manual is published by: **GLUNZ & JENSEN A/S**
Selandia Park 1
DK-4100 Ringsted
Denmark
Phone: +45 5768-8181
E-mail: gjhq@glunz-jensen.com
Internet: www.glunz-jensen.com

Copyright © 2014 by GLUNZ & JENSEN A/S.

Part 0: Introduction

Reservations

- This manual was written and illustrated using the best possible information available at the time of publication.
- Any differences between this manual and the equipment reflect improvements introduced after the publication of the manual.
- Changes, technical inaccuracies and typographic errors will be corrected in subsequent editions.
- As a part of our policy of continuous improvement, we reserve the right to alter design and specifications without further notice.

Pre-installation instructions

The instructions in this Pre-installation Manual allow the customer and the service technician to prepare the installation site for the equipment and for the installation itself.

- Never install the equipment in explosive environments.
- It is the responsibility of the owner and operator(s) of the equipment that the installation is made in accordance with local regulations, and by engineers authorized to carry out pneumatic and electrical installations.
- The manufacturer cannot be held responsible for any damage caused by incorrect installation of the equipment.



Only qualified service technicians are allowed to unpack and install the equipment.



When preparing the installation site please take into consideration that this equipment is for restricted access locations only!

Notes, cautions, and warnings!

Throughout the manual warnings, cautions, and notes are written in bold like the example below:



Electrical installation must conform to local regulations and guidelines.



Symbol	Meaning	Explanation
	Note	The operator should observe and/or act according to the information in order to obtain the best possible function of the equipment.
	Caution	The operator must observe and/or act according to the information in order to avoid any mechanical or electrical damage to the equipment.
	Warning	The operator must observe and/or act according to the information in order to avoid any personal injury.

Table of contents

Part 0: Introduction	0-3
Reservations	0-3
Pre-installation instructions	0-3
Notes, cautions, and warnings !	0-4
Part 1: Transportation	1-1
When the unit arrives	1-1
Storing the unit before installation	1-1
The crate	1-1
Dimensions and weight	1-1
Checking the crate for damage	1-2
Handling the crate	1-2
Transporting the unit	1-3
Lifting the crate	1-3
Available width for transport	1-3
Part 2: Installation requirements	2-1
Environmental requirements	2-1
Accessories to be provided by customer for connections	2-1
Space requirements	2-2
Free space around the equipment	2-2
Equipment dimensions	2-3
Compressed air connection	2-4
Electrical requirements	2-5
Main power connection	2-5
Main power outlet	2-5
Power cable	2-5
Electrical specifications	2-6
Installation requirements for power supply	2-6
Fuses	2-6
Power consumption	2-6
Part 3: Pre-installation check list	3-1

Part 1: Transportation

When the unit arrives

Storing the unit before installation

The crated equipment will usually be delivered some time before the arrival of the service technician. In which case you should prepare an appropriate place indoors to store the crated unit.

The crate

Dimensions and weight

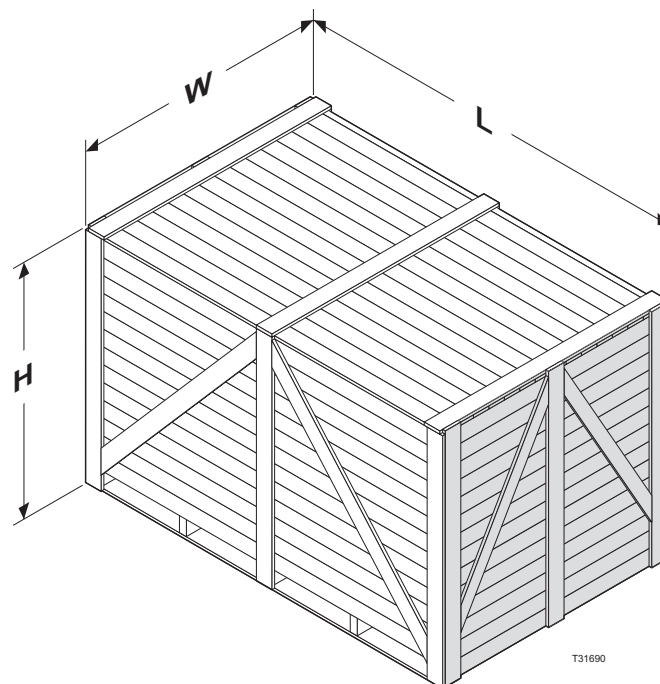

Width (W)	160 cm (64")
Length (L)	360 cm (141.7")
Height (H)	220 cm (86.6")
Weight crated (\pm 5%)	3000 kg (6614 lb)
Weight without crate	2650 kg (5842 lb)

Checking the crate for damage

Check if the crate is damaged at the time of delivery. Take note of the damage before you allow the service technician to unpack the equipment. Provide a detailed description or take a photograph of the damage.



Report any damage to the crate to the transport company.

Handling the crate

The icons on the crate indicate how to handle the crate during transport and storage:



Ensure that the side indicated by the arrows is always up



Handle the crate with care.



Never expose the crate to water, or place it in a high-humidity area.



Do not stack the crates.



Do not tilt the crate.

T32326

Transporting the unit

Lifting the crate

The equipment is supplied in a wooden crate. **The equipment is very heavy.** To lift the crate a fork-lift truck is required.

Place the forks under the two lowest cross beams.

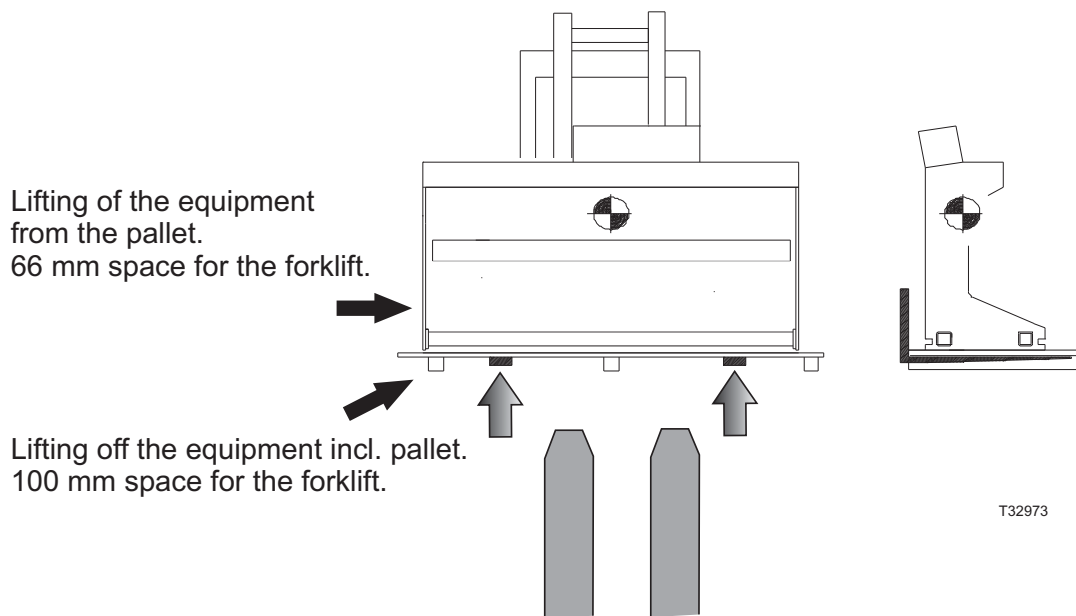

Available width for transport

Depending on the width of the door(s) through which the equipment has to be transported to the installation site, the service technician may have to perform the actions described in the table below:

If width of the door is...	Then...
> 1650 mm	No action is required as the crated equipment can be transported immediately to the installation site.
1650 -960 mm	The service technician has to unpack the equipment.

Part 2: Installation requirements



This equipment must be installed in restricted access locations only.



Check the delivery route to the installation location for necessary clearance and remove all obstructions.

Environmental requirements

Provide a heating and ventilating system capable of maintaining room temperature between 15 and 25°C (59 and 77°F) and relative humidity of max. 80%.

Accessories to be provided by customer for connections

- Cable for the main power connection.
- Hose for the compressed air supply.

Space requirements

Free space around the equipment

Decide where the equipment shall be placed and make sure that the free space around the equipment makes servicing possible.

The recommended minimum free space around the equipment is specified in the illustrations below:

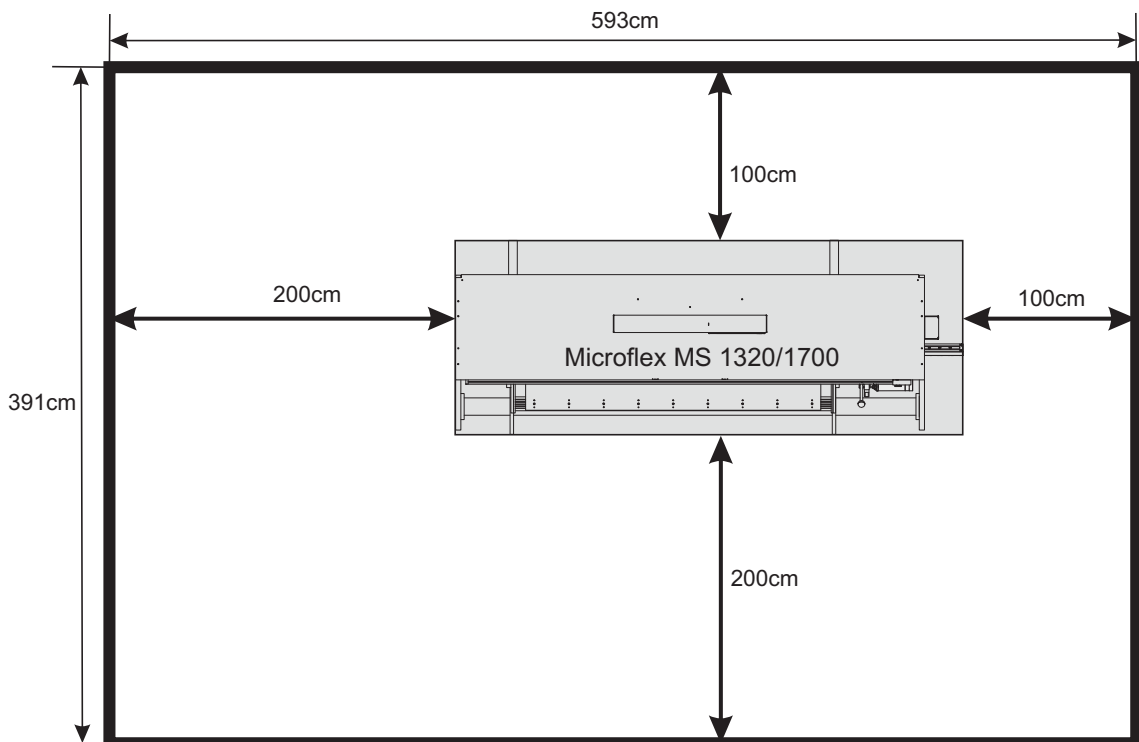

Equipment dimensions

Side view

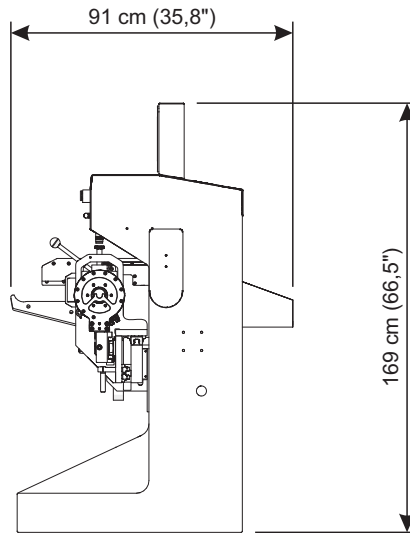

Top view

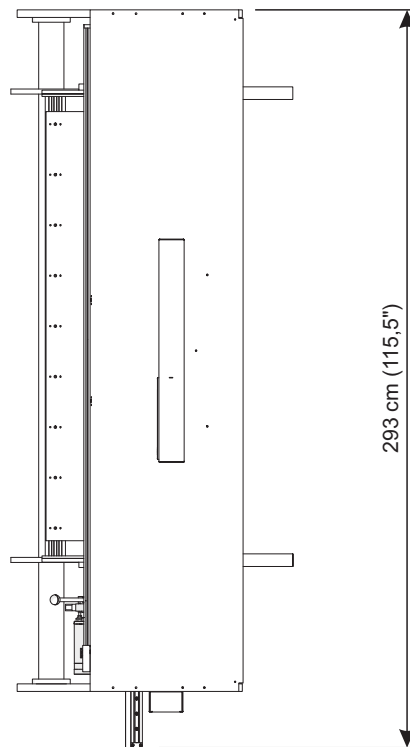

T11394

Compressed air connection



The compressed air must be clean and dry!

Air pressure:

7 bar

Air consumption for the equipment:

12 litres per minute

Air consumption for the sleeve change:

300 litres per minute

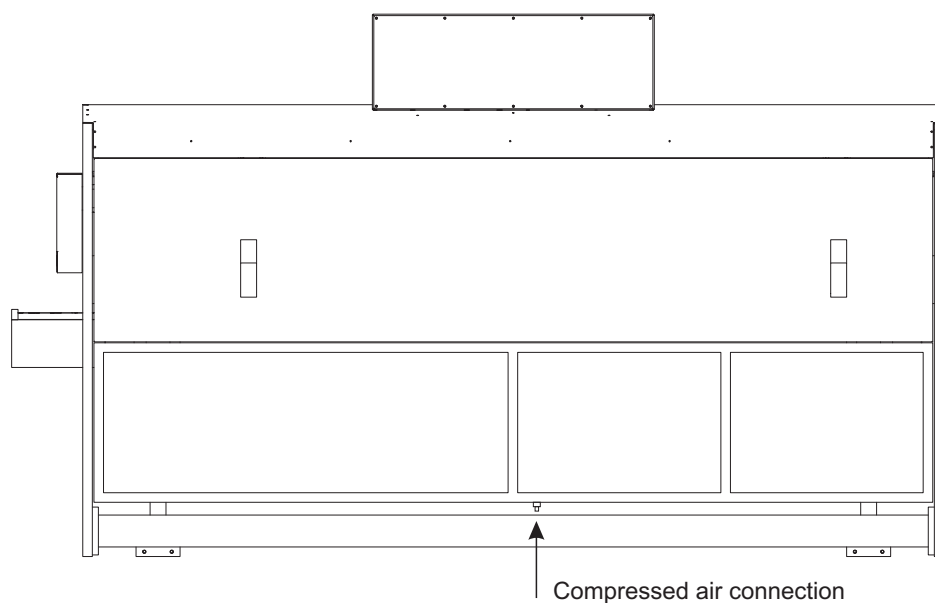

T11395

Electrical requirements

 Electrical installation must conform to local regulations and guidelines.

Main power connection

The main power connection is made in the equipments terminals located at the back under the cover as shown in the illustration below.

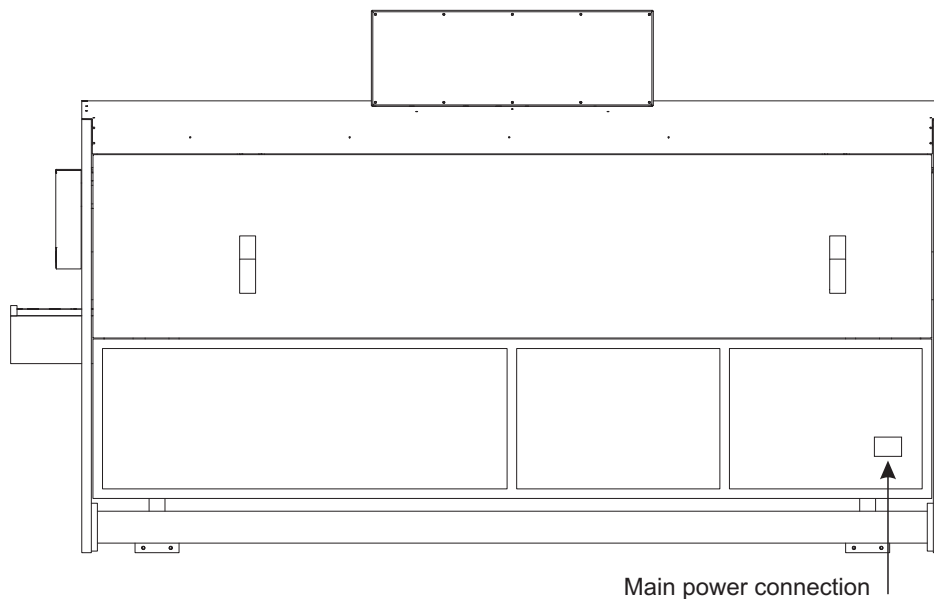

T11396

Main power outlet

Provide a main power outlet close to the installation site. The table on the next page indicates the applicable power supply types.

Power cable

The cable for the main power connection is not included. See the power supply table on the next page. The table also shows recommended power supply cables.

 When deciding what type of cable to use take into account the chemical resistance (chemicals may leak onto cable) and the mechanical resistance (operator may step onto cable).
The conductors in the power supply cable should be of copper.
Provide for additional cable protection, e.g. cable covers, if cable is exposed to heavier transport such as fork-lift trucks etc.

 The equipment is Class 1 equipment. Therefore, the equipment must be connected to earth to avoid electrical shocks.

Electrical specifications

Installation requirements for power supply



The requirements below are specifications for preparing the installation protection. It is important to prepare the fuses/circuit breakers with adequate capacity as specified here.



Specifications on the equipment's name plate is the actual input current and will thus not be identical to below mentioned.

	Supply / fuse	Recommended cable type
	3W + N + PE, 400 VAC 3 x 16 A, 50-60 Hz	Min. 5 x 2.5 mm ² type H07RNF
All	Voltage tolerance ±10%	

Fuses



The fuses must have a breaking capacity of min. 100 kA.
If using automatic circuit breakers make sure that they are Type D.







Only all-current sensitive fault current breakers suitable for inverter operation may be used.

Power consumption

	Power consumption at ...
	400 VAC operation: approx. 1.2 kWh (4,100 BTU/hour)
	Stand-by: approx. 0.5 kWh (1,710 BTU/hour)

Switching the mains power

-  Cyclic power switching is permitted every 60 seconds: Jog mode is not permitted.
-  If switching is too frequent, the equipment protects itself by means of high-resistance isolation from the system. After a rest phase of a few minutes the equipment is ready to start once again.
-  TN network and TT network: Permitted without restriction.
IT network (insulated centre point): Not permitted.
-  In the event of a ground fault the voltage stress is around twice as high, and creepages and clearances to EN50178 are no longer maintained.
-  The supply must be made in a way so the live wire always will be connected to the L1/L2/L3 terminal and the neutral wire always connected to the N terminal in the electrical panel.

Part 3: Pre-installation check list

Please ask the customer to answer the following questions in order to ensure a trouble-free installation of the equipment:

- 1. Delivery of the crate and transport to the installation site** **YES NO**
- A. Is there a place indoors where the crated equipment can be stored temporarily.
 - B. Is there a hand-powered pallet mover, a fork-lift truck or any other lifting device available?
 - C. Can the crate be transported directly to the installation site?
See minimum width specifications on page 1-3.
 - D. Is it sufficient to unpack the equipment before it is transported to the installation site?
See minimum width specifications on page 1-3.
 - E. Are there other factors (stairs, elevators, corners, obstacles, etc.) which should be taken into account when transporting the crate or equipment?
If so, explain:
.....
.....
.....

2. Power supply

- A. Make a note of the present supply specifications:

No. of Phases	Voltage	Fused by	
Neutral Wire?	Earth Wire?	Frequency	YES NO
- B. Has a connection box been provided to connect the equipment to the mains?
- C. Is the customer aware that he/she should have to (or order) all supplies (cables, fuses, etc.) necessary to connect the equipment to the mains?
- D. Is there a local electrician available?
- E. Are there any known problems in the building where the equipment will be installed?
If so, explain:
.....
.....
.....

3. Compressed air supply

YES NO

- A. Is there a connection hose to supply compressed air according to page 2-4?

 4. Disposition of the various supplies and equipment on the installation site: