



Pre-installation Guide

FlexMount 1320/1700

▶ **IMPORTANT**

Please follow the instructions in this guide when preparing the installation site prior to arrival and installation of the equipment.

GLUNZ & JENSEN 

June 30th, 2023
Edition BB, Part No 10076645
English (en-us) Original version

(Blank)

About this manual

This manual applies to the Mounting Table **FlexMount 1320/1700**.

This manual is published by:

Glunz & Jensen A/S

Selandia Park 1

DK-4100 Ringsted

Denmark

Phone: +45 57 68 81 81

E-mail: gj@glunz-jensen.com

Internet: www.glunz-jensen.com

Copyright © June, 2023 by Glunz & Jensen A/S

Table of Contents

About this manual	3
Table of Contents	4
Introduction	5
Reservations	5
Introduction	5
Notes, Cautions and Warnings!	5
Transportation	7
When the equipment arrives	7
Storing of the equipment prior to the installation	7
The crate	7
Crate Dimensions	7
Weight	8
Checking the crate for damage	8
Handling the crate	8
Lifting the crate	9
Required width of passage and doorways	9
Installation requirements	11
Heating and ventilation	11
Floor stability	11
Space requirements	12
Free space around the equipment	12
Dimensions	13
Connections	14
Compressed air	15
Electrical requirements	15
Main power outlet	15
Power cable	15
Electrical specifications	16
Power supply requirements	16
Power consumption	16
Checklist	17

Introduction

Reservations



- This manual was written and illustrated using the best possible information available at the time of publication.
- Any differences between this manual and the equipment reflect improvements introduced after the publication of the manual.
- Changes, technical inaccuracies and typographic errors will be corrected in subsequent editions.
- As a part of our policy of continuous improvement, we reserve the right to alter design and specifications without further notice.

Introduction

The instructions in this Pre-installation Guide help the customer and the Service Technician to prepare the installation site for the arrival and installation of the equipment.

Notes, Cautions and Warnings!

Notes, cautions, and warnings in this manual are used and categorized as described below:

Symbol	Meaning	Explanation
	NOTE	The operator should observe and/or act according to the information in order to obtain the best possible function of the equipment.
	CAUTION	The operator must observe and/or act according to the information in order to avoid any mechanical or electrical damage to the equipment.
	WARNING	The operator must observe and/or act according to the information in order to avoid any personal injury.



(blank page)

Transportation

When the equipment arrives

Storing of the equipment prior to the installation

The equipment will usually be delivered some time before the arrival of the service technician. Provide for an appropriate place indoor to store the crated equipment until the service technician arrives.

The crate

Crate Dimensions

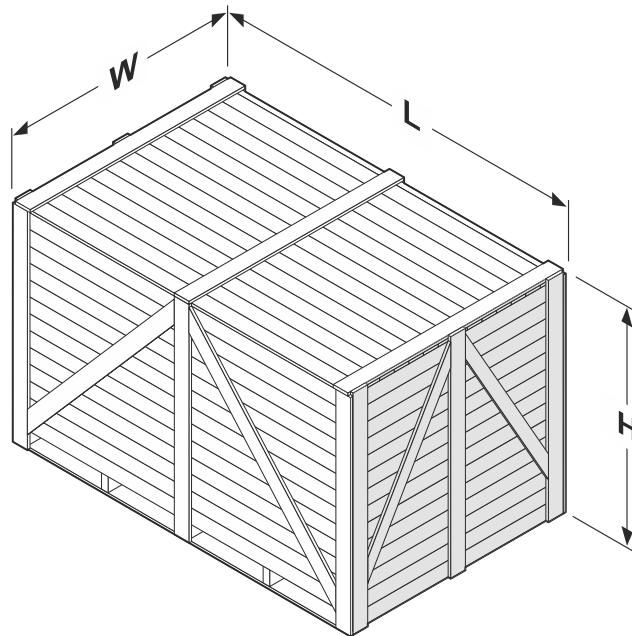

	FlexMount 1320	FlexMount 1700
Length (L)	1600 mm (64.0")	1600 mm (64.0")
Width (W)	3600 mm (141.7")	3600 mm (141.7")
Height (H)	2200 mm (86.6")	2200 mm (86.6")

Weight

	FlexMount 1320	FlexMount 1700
With crate	3000 kg (6614 lbs)	3000 kg (6614 lbs)
Without crate	2650 kg (5842 lbs)	2650 kg (5842 lbs)

Checking the crate for damage

Upon receipt of the machinery, check if the crate is damaged on delivery at the customer's address. Make notes of any damages, before opening the crate. Provide a detailed description and take a photograph of the damage.

Report any damage of the crate to the shipping company and notify the insurance agent, if appropriate, before the mishandled package is open.

Check the Tilt watch and the Shock watch label that the red mark has not appeared and compare their serial numbers with those on the box label whether they match.

Handling the crate

The icons on the crate indicate how to handle the crate during transport and storage:



Ensure that the side indicated by the arrows is always up.



Handle the crate with care



Never expose the crate to water, or place it in a high-humidity area.



Do not stack the crates.





Do not tilt the crate.

Lifting the crate

The equipment is supplied in a wooden crate on a pallet.

A forklift truck or two persons and a hand powered pallet mover are required for lifting the crate on arrival and for lifting the equipment off the pallet.

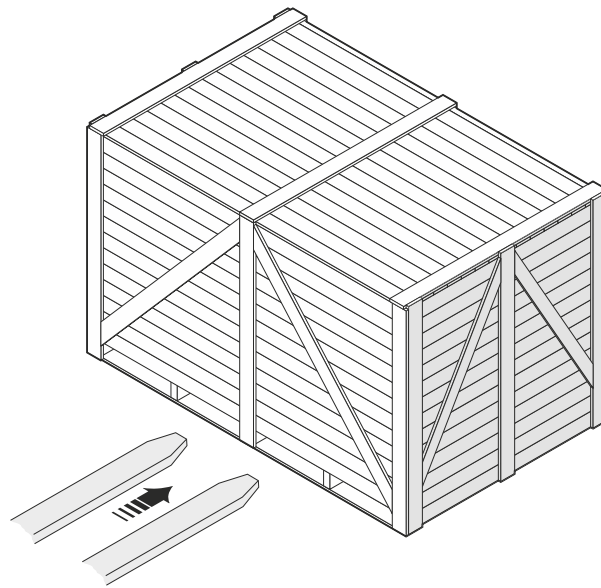

 **WARNING:** The equipment is very heavy equipment. It is only possible to lift the equipment off the pallet using a forklift truck or a pallet mover.

 **CAUTION:** Make sure to provide a forklift designed and adequate for lifting a crate of the size and weight as specified in this manual.



Required width of passage and doorways

Depending on the width of the passage- and doorways through which the equipment has to be transported to the installation site, the service technician may have to perform the actions described in the table below:

If width of the doorway is ...	FlexMount 1320	FlexMount 1700	Then ...
More than	1700 mm (66.9")	1700 mm (66.9")	The crated equipment can be transported immediately to the installation site.  CAUTION: May require machine moving skates suitable for transport of very heavy equipment.
Less than but more than	1700 mm (66.9") 1070 mm (42.1")	1700 mm (66.9") 1070 mm (42.1")	The Service Technician has to unpack the equipment.  CAUTION: May require machine moving skates suitable for transport of very heavy equipment.



(blank page)

Installation requirements



WARNING: The equipment must be installed in restricted access locations only.

Heating and ventilation

Provide a heat and ventilation system capable of maintaining room temperature between 15°C (59°F) and 30°C (86°F) and a relative humidity (non condensing) of min. 40% and max. 60%.

For heat emission see "Power consumption" on page 16.

Floor stability



WARNING: Note the very heavy weight of the equipment!

Please refer to weight and dimensions of the equipment when calculating footprint and load for preparation of the installation site.

The floor should have a variation in height of no more than 6 mm per meter (1/4" over 40" length). If in doubt about the floor loading, please consult a structural engineer.

Space requirements

Free space around the equipment

Decide for a proper installation site for the equipment and make sure that the free space around the equipment makes servicing possible.

The recommended minimum free space around the equipment is specified in the next illustration.

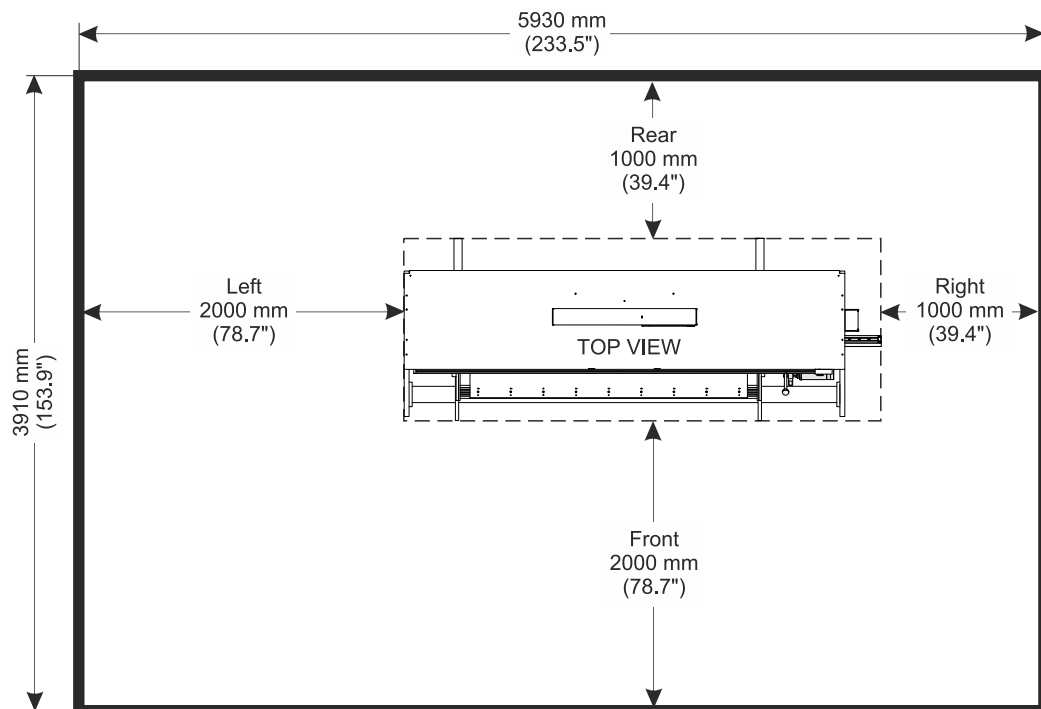

Dimensions

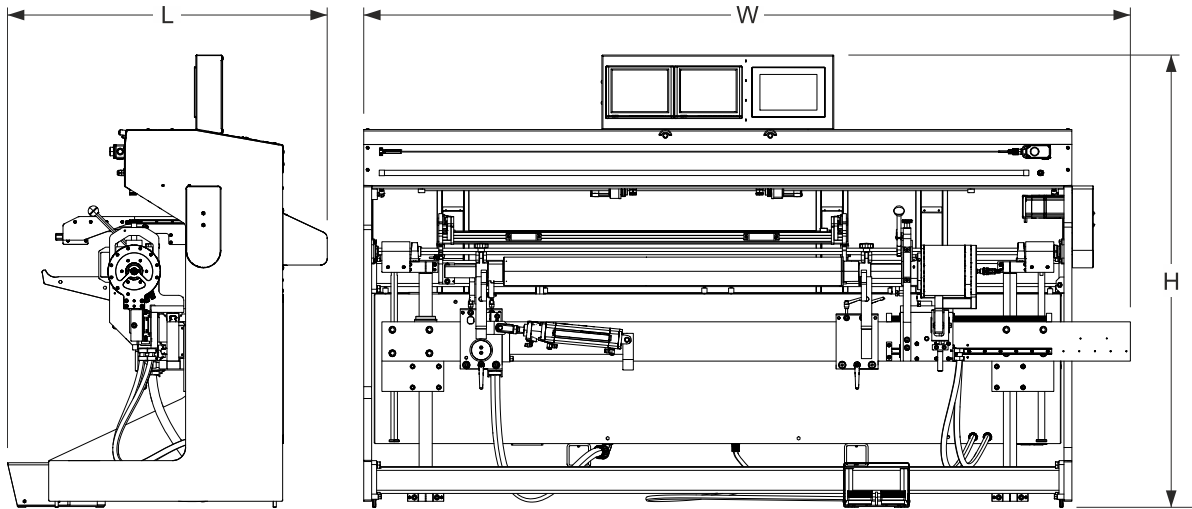

	FlexMount 1320	FlexMount 1700
Width (W)	2930 mm (115.5")	2930 mm (115.5")
Length (L)	1220 mm (48.0")	1220 mm (48.0")
Height (H)	1700 mm (66.9")	1700 mm (66.9")

Connections

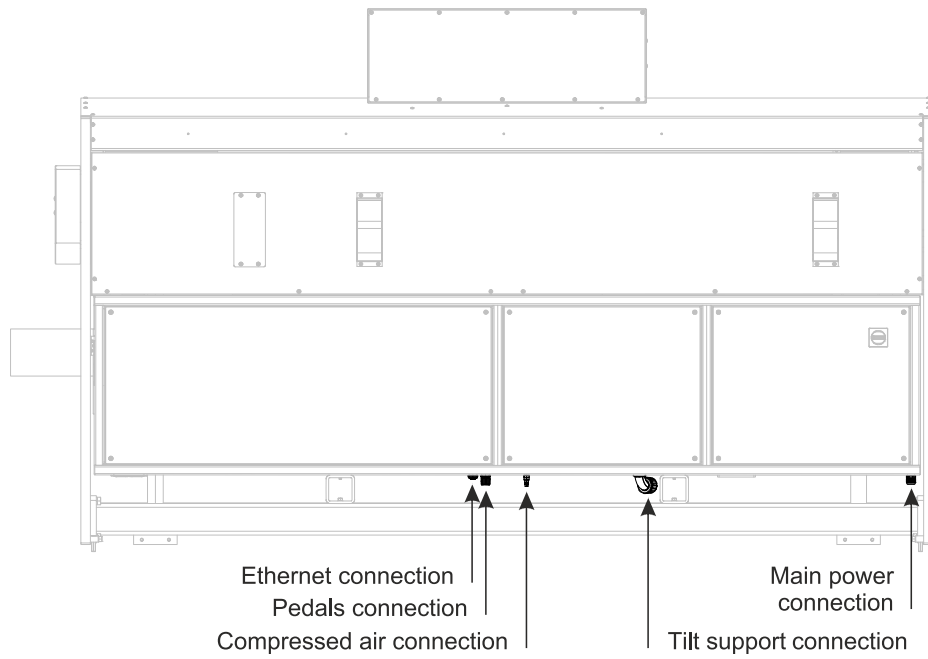

Compressed air

Description	FlexMount 1320	FlexMount 1700
Min. pressure	7 bar (102 psi)	7 bar (102 psi)
Max. pressure	10 bar (145 psi)	10 bar (145 psi)
Volume	300 l/min (10.6 CFM)	300 l/min (10.6 CFM)
Hose size	D6 mm	D6 mm

Air volume for the regular equipment functionality is on average 12 l/min (0.42 CFM).

Air volume for the sleeve change operation is up to 300 l/min (10.6 CFM).

Electrical requirements



WARNING: Electrical installation, all cabling and cabling connections, fusing and isolation must conform to local and/or national regulations and guidelines.

Main power outlet

Provide an mains power-outlet with an electrical plug lockout close to the installation site. The table showing "Power supply requirements" on the next page indicates the applicable power supply types.

Power cable



NOTE: The cable for the main power connection is not included with the equipment. Please refer to the recommended cable types described in "Power supply requirements" on the next page.



WARNING: The equipment is Class 1 equipment. Therefore, the equipment must be connected to earth to avoid electrical shocks.

Please be aware of double pole/neutral fusing.



CAUTION:

The conductors in the power supply cable should be of copper.

Provide for additional cable protection, e.g. cable covers, if cable is exposed to heavier transport such as fork-lift trucks etc.

Electrical specifications

Power supply requirements



CAUTION: The requirements below are specifications for preparing the installation protection. The fuses/circuit breakers must be prepared according to local regulations, and with adequate capacity as specified here. The circuit breakers must be suitable for inventor operation.



NOTE: Specifications on the equipment's name plate is the actual input current and will thus not be identical to below mentioned.

FlexMount 1320/1700

	Supply *	Fuses and cables types	
		FlexMount 1320	FlexMount 1700
EUR	3W + N + PE, 400 VAC, 50/60 Hz	Fused by 3 × 16 Amps Cable type: Min. 5 × 2.5 mm ² , type H07 RNF	Fused by 3 × 16 Amps Cable type: Min. 5 × 2.5 mm ² , type H07 RNF

*) Voltage tolerance ± 10%



NOTE: The power cable(s) must be in accordance with local regulations.



WARNING: Please be aware of double pole/neutral fusing.



CAUTION: The fuses must have a breaking capacity of min. 100 kA.



CAUTION: If a circuit breaker of type ELCB, RCCB, or GFCI is used where leakage to ground is detected, the trip sensitivity must be 300 mA.

Power consumption

	FlexMount 1320	FlexMount 1700
In operate, per phase (±10%), max.	1200 W (4100 BTU)	1200 W (4100 BTU)
In stand-by	500 W (1710 BTU)	500 W (1710 BTU)

Checklist

The customer should answer the following questions in order to ensure a trouble-free installation of the equipment and send the completed pre-installation checklist to the service technician who is responsible for coordination of the installation.

1.	Delivery of the crate and transport to the installation site	YES	NO
	A. Is there a place indoor where the crated equipment can be stored temporarily?	<input type="radio"/>	<input type="radio"/>
	B. Is there a hand-powered pallet mover, a forklift truck or any other lifting device available? Please refer to "Transportation" on page 7.	<input type="radio"/>	<input type="radio"/>
	C. Can the crate be transported directly to the installation site? See "Required width of passage and doorways" on page 9.	<input type="radio"/>	<input type="radio"/>
	D. Is it necessary to unpack the equipment before it is transported to the installation site? See "Required width of passage and doorways" on page 9.	<input type="radio"/>	<input type="radio"/>
	E. Are there other factors (stairs, elevators, corners, obstacles, etc.) which should be taken into account when transporting the equipment? If YES, please describe:	<input type="radio"/>	<input type="radio"/>
2.	Power supply	YES	NO
	A. Make a note of the present supply specifications:		
	Number of phases: _____ Neutral wire? <input type="radio"/>		
	Voltage (V): _____ Earth wire? <input type="radio"/>		
	Fused by (Amps): _____		
	Frequency (Hz): _____		
	B. Has a suitable, isolated connection box been provided to connect the equipment to the mains?	<input type="radio"/>	<input type="radio"/>
	C. Has the customer provided/ordered all supplies (cables, fuses, etc.) necessary to connect the equipment to the mains?	<input type="radio"/>	<input type="radio"/>
	D. Is there a house electrician available?	<input type="radio"/>	<input type="radio"/>
	E. Are there any known problems in the building where the equipment will be installed? If YES, please describe which:	<input type="radio"/>	<input type="radio"/>

3. **Comments and questions**
