



Pre-installation Guide

Rinse/Gum Unit 85/125/165

▶ **IMPORTANT**

Please follow the instructions in this guide when preparing the installation site prior to arrival and installation of the equipment.

GLUNZ & JENSEN 

June 13th, 2023
Edition AA, Part No 10111903
English (en-us) Original version

(Blank)

About this manual

This manual applies to the Rinse/Gum Unit **Rinse/Gum Unit 85/125/165**.

This manual is published by:

Glunz & Jensen A/S

Selandia Park 1

DK-4100 Ringsted

Denmark

Phone: +45 57 68 81 81

E-mail: gj@glunz-jensen.com

Internet: www.glunz-jensen.com

Copyright © June, 2023 by Glunz & Jensen A/S

Table of Contents

About this manual	3
Table of Contents	4
Introduction	5
Reservations	5
Introduction	5
Notes, Cautions and Warnings!	5
Transportation	7
When the equipment arrives	7
Storing of the equipment prior to the installation	7
The crate	7
Crate Dimensions	7
Weight	8
Checking the crate for damage	8
Handling the crate	8
Lifting the crate	9
Required width of passage and doorways	10
Installation requirements	11
Heating and ventilation	11
Cleaning facilities	11
Space requirements	12
Free space around the equipment	12
Water supply and drains	13
Water supply	13
Environmental requirements	14
Heating and ventilation	14
Drains	14
Electrical requirements	15
Main power connection	15
Main power outlet	15
Power cable	16
Electrical specifications	17
Power supply requirements	17
Power consumption	18
Checklist	19

Introduction

Reservations



- This manual was written and illustrated using the best possible information available at the time of publication.
- Any differences between this manual and the equipment reflect improvements introduced after the publication of the manual.
- Changes, technical inaccuracies and typographic errors will be corrected in subsequent editions.
- As a part of our policy of continuous improvement, we reserve the right to alter design and specifications without further notice.

Introduction

The instructions in this Pre-installation Guide help the customer and the Service Technician to prepare the installation site for the arrival and installation of the equipment.

Notes, Cautions and Warnings!

Notes, cautions, and warnings in this manual are used and categorized as described below:

Symbol	Meaning	Explanation
	NOTE	The operator should observe and/or act according to the information in order to obtain the best possible function of the equipment.
	CAUTION	The operator must observe and/or act according to the information in order to avoid any mechanical or electrical damage to the equipment.
	WARNING	The operator must observe and/or act according to the information in order to avoid any personal injury.



(blank page)

Transportation

When the equipment arrives

Storing of the equipment prior to the installation

The equipment will usually be delivered some time before the arrival of the service technician. Provide for an appropriate place indoor to store the crated equipment until the service technician arrives.

The crate

Crate Dimensions

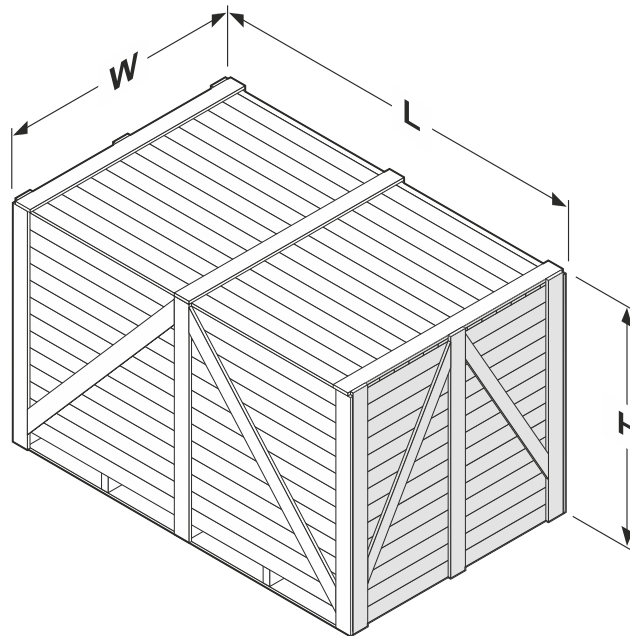

	Rinse/Gum Unit 85	Rinse/Gum Unit 125	Rinse/Gum Unit 165
Length (L)	1895 mm (73.8")	2284 mm (89.9")	2734 mm (107.6")
Width (W)	1000 mm (39.4")	1000 mm (39.4")	1000 mm (39.4")
Height (H)	1491 mm (58.7")	1491 mm (58.7")	1491 mm (58.7")

Weight

	Rinse/Gum Unit 85	Rinse/Gum Unit 125	Rinse/Gum Unit 165
With crate	392 kg (864 lbs)	503 kg (1109 lbs)	587 kg (1294 lbs)
Without crate	262 kg (578 lbs)	353 kg (778 lbs)	412 kg (908 lbs)

Checking the crate for damage

Upon receipt of the machinery, check if the crate is damaged on delivery at the customer's address. Make notes of any damages, before opening the crate. Provide a detailed description and take a photograph of the damage.

Report any damage of the crate to the shipping company and notify the insurance agent, if appropriate, before the mishandled package is open.

Check the Tilt watch and the Shock watch label that the red mark has not appeared and compare their serial numbers with those on the box label whether they match.

Handling the crate

The icons on the crate indicate how to handle the crate during transport and storage:



Ensure that the side indicated by the arrows is always up.



Handle the crate with care



Never expose the crate to water, or place it in a high-humidity area.



Do not stack the crates.



Do not tilt the crate.

Lifting the crate

The equipment is supplied in a wooden crate on a pallet.

A forklift truck or two persons and a hand powered pallet mover are required for lifting the crate on arrival and for lifting the equipment off the pallet.



WARNING: The equipment is very heavy equipment.

It is only possible to lift the equipment off the pallet using a forklift truck or a pallet mover.



CAUTION: Make sure to provide a forklift designed and adequate for lifting a crate of the size and weight as specified in this manual.

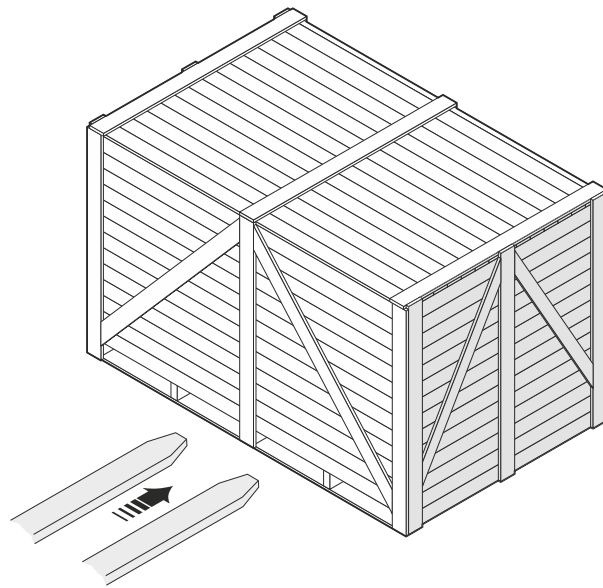

Required width of passage and doorways

Depending on the width of the passage- and doorways through which the equipment has to be transported to the installation site, the service technician may have to perform the actions described in the table below:

If width of the doorway is ...	85	125	165	Then ...
More than	1200 mm (47.2")	1200 mm (47.2")	1200 mm (47.2")	No action is required as the crated equipment can be transported immediately to the installation site.
Less than but more than	1200 mm (47.2") 1000 mm (39.4")	1200 mm (47.2") 1000 mm (39.4")	1200 mm (47.2") 1000 mm (39.4")	The Service Technician has to unpack the equipment.
Less than	1000 mm (39.4")	1000 mm (39.4")	1000 mm (39.4")	The Service Technician has to remove panels and perhaps disassemble parts of the equipment.

Installation requirements

Heating and ventilation

Provide a heat and ventilation system capable of maintaining room temperature between 15°C (59°F) and 25°C (77°F) and a relative humidity (non condensing) of min. 40% and max. 80%.

For heat emission see "Power consumption" on page 18.

Cleaning facilities

It is essential to have easy access to a sink and a water tap with hot water where rollers, guides, and brushes can be washed.

	Minimum recommended size of the sink
Rinse/Gum Unit 85	100 × 40 cm (39.4 × 16")
Rinse/Gum Unit 125	140 × 40 cm (55.1 × 16")
Rinse/Gum Unit 165	180 × 40 cm (70.9 × 16")

Space requirements

Free space around the equipment

Decide for a proper installation site for the equipment and make sure that the free space around the equipment makes servicing possible.

The recommended minimum free space around the equipment is specified in the next illustration.



CAUTION: For CTP On-line, the space requirements at the equipment front has to be decided separately.

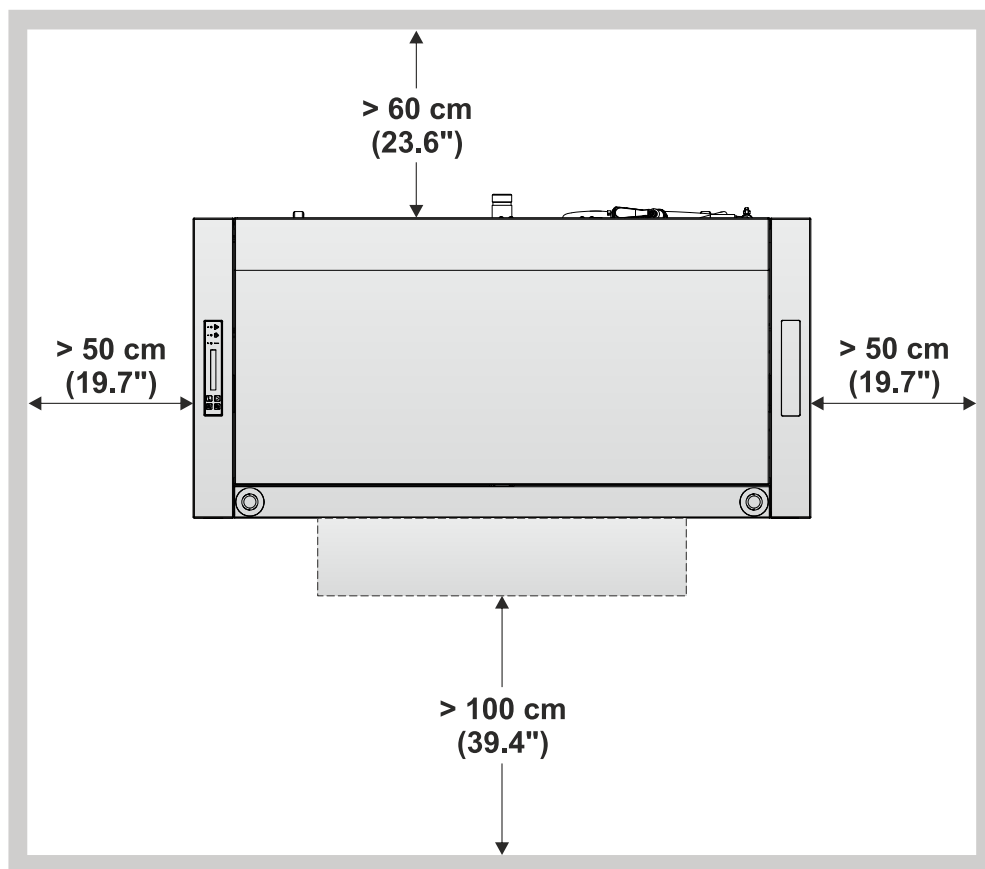

Water supply and drains

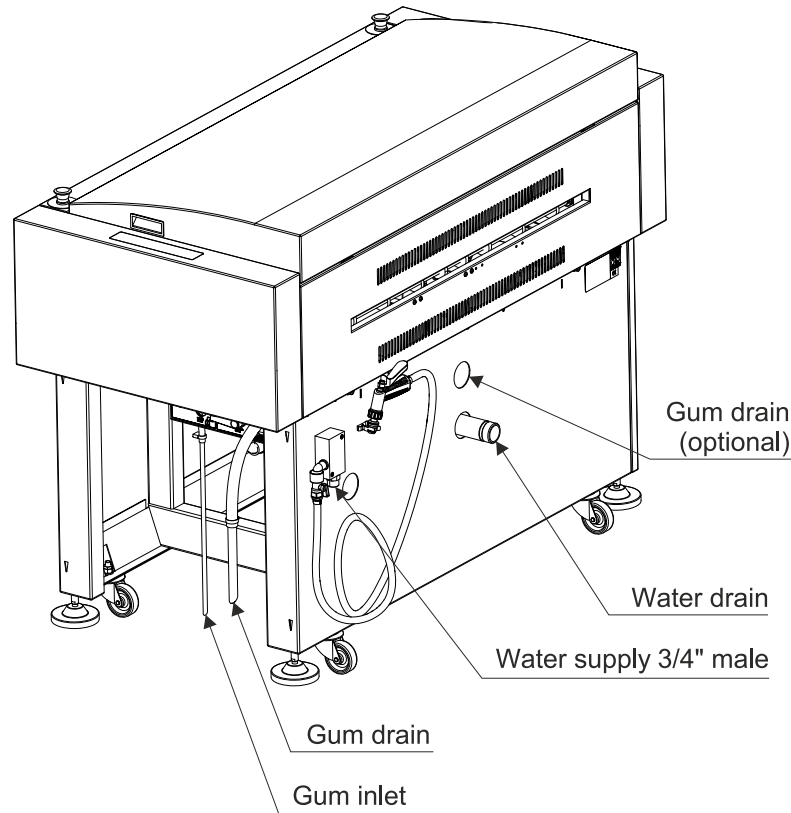

Prepare the installation site for water supply and drain connections according to the illustration. Please also refer to the "Space requirements" on the previous page.

Water supply



CAUTION: Water supply must be equipped with a DIN 1988-approved return valve.

A water tap should be installed next to the installation site of the machine. Max. distance to the water tap should be 5 m (16.4 ft). The tap must be able to accept a reinforced hose minimum 15 mm (19/32") inner diameter. This hose is not included with the machine.

Another possibility is to provide the machine with tempered water through a thermostatically controlled mixing valve.

The water supply must be capable of supplying a minimum of 20 litres/min (5 US gal./min) at a pressure of no less than 2.75 bar (40 psi), and fitted with a check valve.

Environmental requirements

Heating and ventilation

Provide a heat and ventilation system capable of maintaining room temperature between 15°C (59°F) and 25°C (77°F) and a relative humidity (non condensing) of min. 40% and max. 80%.

For heat emission see "Power consumption" on page 18.



WARNING: The ventilating system must be capable of renewing the air around the processor effectively. The best solution will be a hood with a d100-120 mm exhaust hose covering the exit of the processor with a capacity of removing min. 300 m³/h. Alternatively an exhaust system removing the air from the room must have a capacity of min. 800 m³/h. In both cases fresh air should be provided at floor level through light tight ventilation openings.

Be aware that the airflow must pass from the setter and across the processor – never the opposite way around.

Drains

All drain hoses must have a positive fall from the equipment to the drain.



NOTE: Never lead chemicals into public drainage systems as most chemical solutions are strong pollutants.

Contact your supplier of chemicals if you need information about the chemical solution with regard to personal safety.

Refer to local authorities for information regarding environmental protection and disposal of waste chemicals.

Electrical requirements

WARNING: Electrical installation, all cabling and cabling connections, fusing and isolation must conform to local and/or national regulations and guidelines.

Main power connection

The main power connection must be made to the main connector located on the left side of the equipment.

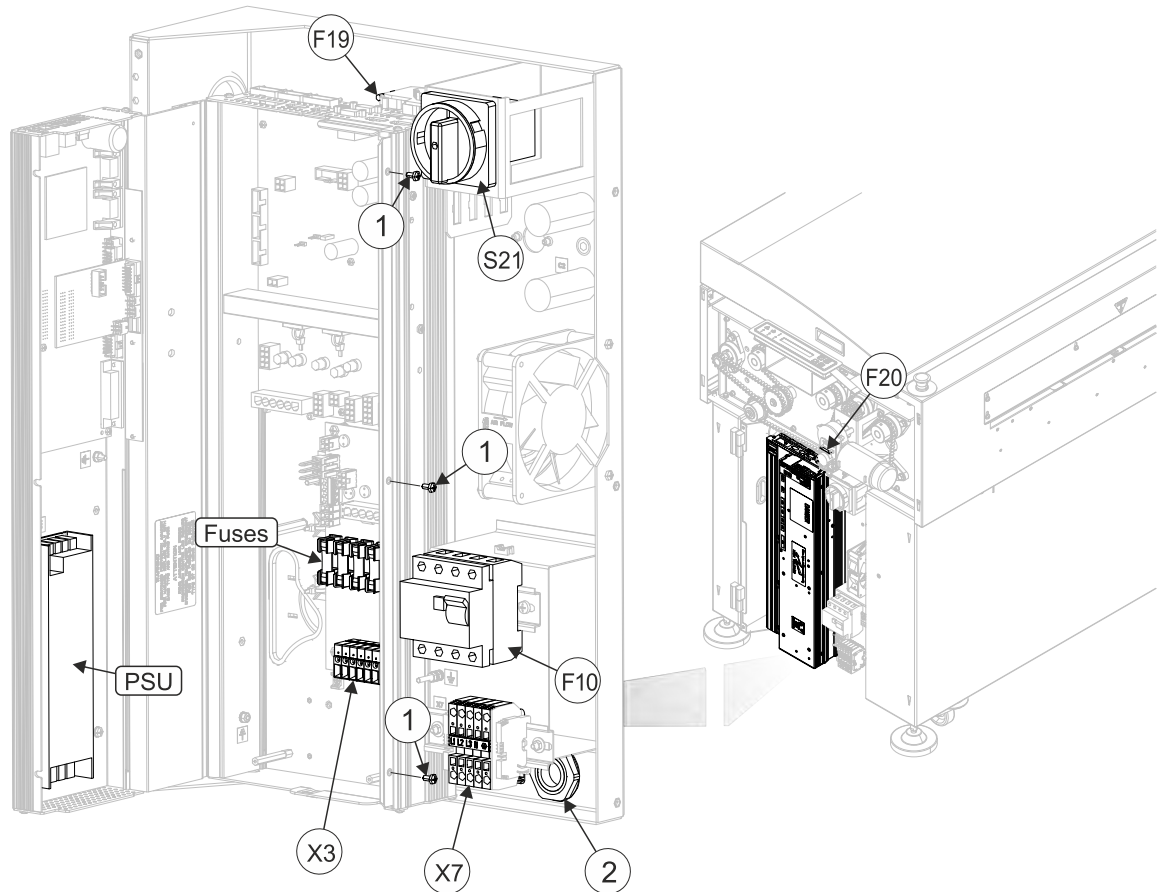

Main power outlet

Provide a mains power-outlet with an electrical plug lockout close to the installation site. The table showing "Power supply requirements" on page 17 indicates the applicable power supply types.

Power cable



NOTE: The cable for the main power connection is not included with the equipment. Please refer to the recommended cable types described in "Power supply requirements" on the facing page.



WARNING: The equipment is Class 1 equipment. Therefore, the equipment must be connected to earth to avoid electrical shocks.

Please be aware of double pole/neutral fusing.



CAUTION:

The conductors in the power supply cable should be of copper.

When deciding what type of cable to use, also consider the chemical resistance (chemicals may leak onto cable) and the mechanical resistance (operator may step onto cable).

Provide for additional cable protection, e.g. cable covers, if cable is exposed to heavier transport such as fork-lift trucks etc.

Electrical specifications

Power supply requirements



CAUTION: The requirements below are specifications for preparing the installation protection. The fuses/circuit breakers must be prepared according to local regulations, and with adequate capacity as specified here. The circuit breakers must be suitable for inventor operation.



NOTE: Specifications on the equipment's name plate is the actual input current and will thus not be identical to below mentioned.

	Supply *	Fuses and cables types		
		Rinse/Gum Unit 85	Rinse/Gum Unit 125	Rinse/Gum Unit 165
EUR	1W + N + PE, 230 VAC, 50/60 Hz	Fused by 1 × 10 Amps Cable type: Min. 3 × 1.5 mm ² , type H07 RNF	Fused by NA Cable type: NA	Fused by NA Cable type: NA
EUR	3W + N + PE, 400 VAC, 50/60 Hz	Fused by 3 × 10 Amps Cable type: Min. 5 × 1.5 mm ² , type H07 RNF	Fused by 3 × 10 Amps Cable type: Min. 5 × 1.5 mm ² , type H07 RNF	Fused by 3 × 10 Amps Cable type: Min. 5 × 1.5 mm ² , type H07 RNF
US	2W + PE, 230 VAC, 50/60 Hz	Fused by 2 × 10 Amps Cable type: Min. 3 × 14 AWG, type SJO	Fused by 2 × 20 Amps Cable type: Min. 3 × 14 AWG, type SJO	Fused by 2 × 20 Amps Cable type: Min. 3 × 14 AWG, type SJO
US	3W + PE, 230 VAC, 50/60 Hz	Fused by 3 × 10 Amps Cable type: Min. 4 × 14 AWG, type SJO	Fused by 3 × 20 Amps Cable type: Min. 4 × 14 AWG, type SJO	Fused by 3 × 20 Amps Cable type: Min. 4 × 14 AWG, type SJO
JAP	2W + PE, 200 VAC, 50/60 Hz	Fused by 2 × 10 Amps Cable type: Min. 3 × 14 AWG, type*	Fused by 2 × 15 Amps Cable type: Min. 3 × 14 AWG, type*	Fused by 2 × 15 Amps Cable type: Min. 3 × 14 AWG, type*
JAP	3W + PE, 200 VAC, 50/60 Hz	Fused by 3 × 10 Amps Cable type: Min. 4 × 14 AWG, type*	Fused by 3 × 15 Amps Cable type: Min. 4 × 14 AWG, type*	Fused by 3 × 15 Amps Cable type: Min. 4 × 14 AWG, type*

*) Voltage tolerance ± 10%



NOTE: The power cable(s) must be in accordance with local regulations.



WARNING: Please be aware of double pole/neutral fusing.



CAUTION: The fuses must have a breaking capacity of min. 100 kA. If using automatic circuit breakers make sure that they are Type D.



CAUTION: If a circuit breaker of type ELCB, RCCB, or GFCI is used where leakage to ground is detected, the trip sensitivity must be 300 mA.



WARNING: High leakage current! Earth connection essential before connecting supply.



WARNING: Connection to mains shall be permanent connection.
Connection via wall plug isn't allowed.

Power consumption

	Rinse/Gum Unit 85	Rinse/Gum Unit 125	Rinse/Gum Unit 165
In operate, per phase (±10%), max.	1900 W (6840 BTU/hour)	3500 W (11900 BTU/hour)	3500 W (11900 BTU/hour)
In stand-by	500 W (1710 BTU/hour)	500 W (1710 BTU/hour)	500 W (1710 BTU/hour)

Checklist

The customer should answer the following questions in order to ensure a trouble-free installation of the equipment and send the completed pre-installation checklist to the service technician who is responsible for coordination of the installation.

1.	Delivery of the crate and transport to the installation site	YES	NO
	A. Is there a place indoor where the crated equipment can be stored temporarily?	<input type="radio"/>	<input type="radio"/>
	B. Is there a hand-powered pallet mover, a forklift truck or any other lifting device available? Please refer to "Transportation" on page 7.	<input type="radio"/>	<input type="radio"/>
	C. Can the crate be transported directly to the installation site? See "Required width of passage and doorways" on page 10.	<input type="radio"/>	<input type="radio"/>
	D. Is it necessary to unpack the equipment before it is transported to the installation site? See "Required width of passage and doorways" on page 10.	<input type="radio"/>	<input type="radio"/>
	E. Are there other factors (stairs, elevators, corners, obstacles, etc.) which should be taken into account when transporting the equipment? If YES, please describe:	<input type="radio"/>	<input type="radio"/>
<hr/>			
<hr/>			
2.	Power supply	YES	NO
	A. Make a note of the present supply specifications:		
	Number of phases: _____ Neutral wire? <input type="radio"/>		
	Voltage (V): _____ Earth wire? <input type="radio"/>		
	Fused by (Amps): _____		
	Frequency (Hz): _____		
	B. Has a suitable, isolated connection box been provided to connect the equipment to the mains?	<input type="radio"/>	<input type="radio"/>
	C. Has the customer provided/ordered all supplies (cables, fuses, etc.) necessary to connect the equipment to the mains?	<input type="radio"/>	<input type="radio"/>
	D. Is there a house electrician available?	<input type="radio"/>	<input type="radio"/>
	E. Are there any known problems in the building where the equipment will be installed? If YES, please describe which:	<input type="radio"/>	<input type="radio"/>
<hr/>			
<hr/>			

- | 3. | Water supply and drains | YES | NO |
|----|--|-----------------------|-----------------------|
| A. | Can a hose ¾" BSP be connected to the water supply tap? | <input type="radio"/> | <input type="radio"/> |
| B. | Is there a large sink (with hot water) for cleaning the equipment? | <input type="radio"/> | <input type="radio"/> |
| C. | Will the equipment be connected to a local waste treatment system? | <input type="radio"/> | <input type="radio"/> |
| D. | Is the tap water temperature adjustable? (If recommended by plate supplier). | <input type="radio"/> | <input type="radio"/> |
| E. | Is the supply water pressure min. 6 bar (87 psi)? | <input type="radio"/> | <input type="radio"/> |
| F. | Is warm water for cleaning of the equipment available? | <input type="radio"/> | <input type="radio"/> |

- | 4. | Heating and ventilation | YES | NO |
|----|--|-----------------------|-----------------------|
| A. | Is the capacity of the air condition/ventilation system adequate with regard to the BTU as specified in "Power consumption" on page 1? | <input type="radio"/> | <input type="radio"/> |
| B. | Is there an exhaust system available to which connection is possible that meets the minimum flow specifications as specified in "Exhaust system requirements" on page 1? | <input type="radio"/> | <input type="radio"/> |

- | 5. | Other | YES | NO |
|----|--|-----------------------|-----------------------|
| A. | Is there an Ethernet connection with open access to the internet available for remote diagnostics? | <input type="radio"/> | <input type="radio"/> |

6. **Comments and questions**
